



INTERNATIONAL MONOHULL OPEN CLASS ASSOCIATION

WORLD SAILING INTERNATIONAL CLASS

Class Rule 2021

[English Version]

Text applicable from 15 April 2021

Version: 4

Amendment included: 1

Compared to version 4.0, the modifications are indicated by a vertical line in the left-hand margin.

Date: 01/07/2021



CONTENTS

CONTENTS	2
INTRODUCTION	4
CHAPTER I – ADMINISTRATION	5
Section A – General points	5
A.1 LANGUAGE	5
A.2 ABBREVIATIONS AND DEFINITIONS.....	5
A.3 AUTHORITY.....	7
A.4 CLASS MANAGEMENT	7
A.5 CLASS MEMBERSHIP.....	7
A.6 CLASS RULE MODIFICATIONS.....	7
A.7 CLASS RULE INTERPRETATIONS	8
A.8 BOAT MEASUREMENT CHECKS AND INSPECTIONS	8
A.9 <i>IMOCA</i> MEASUREMENT CERTIFICATE	9
A.10 DOCUMENT STORAGE.....	10
A.11 EXCEPTIONAL CASES.....	10
Section B – Eligibility.....	11
B.1 CLASS RULES AND CERTIFICATION.....	11
B.2 HULL AND SAIL NUMBERS	11
CHAPTER II – CONDITIONS AND RESTRICTIONS.....	11
Section C – Conditions for racing.....	11
C.1 MOVABLE BALLAST.....	11
C.2 OUTSIDE HELP, SERVO POWER AND MANOEUVRING.....	12
C.3 SAFETY EQUIPMENT	12
C.3.25 PROTECTION.....	16
C.4 MEDICAL AND SURVIVAL TRAINING	17
C.5 ADVERTISING.....	17
C.6 ENERGY / MOTOR	17
C.7. NAVIGATION	18
C.8 IDENTIFICATION.....	19
C.9 BOAT: FITOUT AND EQUIPMENT	19
C.10 BOAT: LIFE ON BOARD	21
C.11 HYDRAULIC SYSTEMS	22
C.12 IDENTIFICATION ON SAILS.....	22
Section D – Hull	22
D.1 FUNDAMENTAL RULES.....	22
D.2 DIMENSIONS.....	22
D.3 HULL MATERIAL LIMITATIONS.....	23
D.4 BUOYANCY VOLUME.....	23
D.5 STABILITY AND RIGHTING MOMENT LIMITS.....	23
D.6 WATER BALLAST	24
D.7 COCKPITS	24
D.8 WATERTIGHT COMPARTMENTS	24
D.9 HATCHES AND EMERGENCY EXITS	25
Section E – Hull Appendages	25
E.1 OVERVIEW	26
E.2 KEEL.....	26
E.3 BULB	27
E.4 FOIL	27
E.5 RUDDER.....	28
Section F – Rig.....	28
F.1 STANDARD MAST	28
F.2 AIR DRAUGHT AND MAST	29

F.3	STANDING RIGGING	29
F.4	OUTRIGGERS.....	29
Section G - Sails.....		29
G.1	OVERVIEW	29
G.2	RESERVED.....	29
G.3	HEADSAILS.....	29
G.4	IDENTIFICATION.....	29
G.5	SAIL MATERIAL.....	30
CHAPTER III – APPENDICES TO THE CLASS RULES.....		30
Appendix A: Grandfather Rules		30
Appendix A-1: Non-standard keel design		34
Appendix B: Standard keel and standard canting system.....		35
Appendix B-1: Standard keel fin		35
Appendix B-2: Standard canting system description		36
Appendix C: Standard mast.....		38
Appendix D: Exemptions from OSR Cat 0		43
Appendix E: Branding plan		43
Appendix F: CRC / Measurers		43
Appendix G: Material limitations, construction methods, finishing products to obtain a CMC.....		44
Appendix H: Lightweight configuration		45
Appendix I: Interpretations		46
These documents are available from the <i>IMOCA</i> class secretariat (contact@imoca.org).....		46
Appendix J: Reserved		46
Appendix K: <i>IMOCA</i> Measurement Certificate and associated documents		46
Appendix K-1: <i>IMOCA</i> Measurement Certificate		46
Appendix K-2: New build declaration form.....		46
Appendix K-3: Documents to be supplied to the CM to obtain a MC/CMC.....		46
Appendix K-4: MC/CMC renewal request form.....		46
Appendix L: Contacts		46
Appendix M: Reserved		47
Appendix N: Sail Identifications		47
Appendix O: Reserved.....		47
Appendix P: Standard Communication System.....		47

INTRODUCTION

The aim of these rules is to establish the restrictions, exclusions and obligations to which all *IMOCA 60s* competing in ocean racing shall comply.

The *IMOCA* Class Rule is an 'Open' rule, which means that anything which is not expressly forbidden, restricted or enforced is permitted.

These rules are constantly evolving, and must be developed in such a way as to prioritise:

- Safety at sea,
- Sporting equity,
- Performance enhancing technical innovation,
- Cost control for boats and projects/campaigns,
- 'Sustainable development' of boats and our sporting practice.

The rules related to equipment manufactured by *IMOCA*'s chosen suppliers apply solely to *IMOCA 60s* fitted with this equipment.

The rules specific to the *Crewed IMOCA Measurement Certificate (CMC)* are written in blue.

The *IMOCA 60* Class has been approved as a World Sailing 'International Class' since 2001.

IMOCA'S APPROACH

- To contribute to the preservation of the environment and the protection of marine biodiversity.
- To put in place all the necessary resources to satisfy the annual goals set out by the *IMOCA* teams' Charter
- To optimise the use of renewable energies with the aim of being self-sufficient in energy by 2024.
- To adhere to World Sailing Environmental Code.
- To measure and understand one's carbon footprint in order to meet the objectives set by the Paris Agreement in 2030.

ENVIRONMENTAL CODE

World Sailing and *IMOCA* are committed to the promotion of care for the environment.

As a general rule and when offshore racing, one shall:

- Use grey and black water holding tanks where fitted and empty them at appropriate pump-out stations on land or when at least 6 nautical miles offshore.
- Use absorbent materials to recover oil in the bilges, and to dispose of these ashore in appropriate containers.
- Use environmentally friendly cleaning products suitable for the marine environment.
- Keep rubbish aboard which can be recycled once ashore, except during long passages when biodegradable rubbish may be thrown overboard.
- Not use 2-stroke engines
- Use solar, wind and hydropower wherever possible.
- Use toilets ashore when the boat is in port.
- Follow the recommendations of the IMO (International Maritime Organization) with regard to biological antifouling products.

CHAPTER I – ADMINISTRATION

Section A – General points

A.1 LANGUAGE

- a) French and English are the two official *IMOCA* languages. In the event of a discrepancy with regard to translation, the French text shall prevail.
- b) The words 'shall' and 'must' indicate something that is mandatory.
- c) With the exception of the titles of the appendices, paragraphs and Notes, the terms printed in:
 - **'Bold'** refer, without exception, to an ERS definition,
 - *'Italic'* refer to an RRS definition,
 - *'Italic'* and *'underlined'* refer to a definition contained in the CR.

A.2 ABBREVIATIONS AND DEFINITIONS

A.2.1 ABBREVIATIONS

CM	<i>IMOCA</i> Chief Measurer
CMC	<i>Crewed IMOCA Measurement Certificate</i>
COLREGS	International Regulations for Preventing Collisions at Sea
CR	<i>IMOCA</i> Class Rules
CRC	<i>IMOCA</i> Class Rules Committee
ERS	Equipment Rules of Sailing
FFV	French Sailing Federation
ISO	International Organization for Standardization
MC	<i>IMOCA</i> Measurement Certificate
NDT	Non-Destructive Material Test
OSR	World Sailing's (WS) Offshore Special Regulations
PBO	Zylon® or equivalent fibres
RM	Righting moment
RRS	Racing Rules of Sailing
SK	Dyneema®, Spectra® (UHMWP fibres)
WS	World Sailing (International Sailing Federation)

A.2.2 DEFINITIONS

A definition in the singular includes the plural and a masculine definition includes the feminine.

Hull appendage: Any item of equipment which is wholly or partially below the sheer line or its extension when fixed or when fully exposed if retractable, attached to the hull shell or another *hull appendage*, and used to affect: stability, leeway, steerage, directional stability, motion damping, trim, displaced volume.

Boat: The equipment used by the crew to take part in a race.

It includes: **hull**, *hull appendage(s)*, **ballast**, **rig**, **sail(s)**, fittings and all other items of equipment used but excludes consumables, **personal equipment** and **portable equipment**.

Boat: hull shell, *hull appendages*, **ballast** and **rig** but not including the structure, the **sails**, fittings and associated attachments, watertight bulkhead doors and emergency exits, companionway hatch(es) and all other items of equipment used, consumables, **personal equipment** and **portable equipment**.

Checklist: The *lightweight configuration* control and compliance document. This document is described in the *measurement protocol*.

Lightweight configuration: This configuration, with its associated conditions, is described in appendix H.

Hull: The hull shell including the transom, if any, the deck including any superstructure, the internal structure including any cockpit(s), and the fittings associated with these parts.

Bunk: A tubular frame with a flexible material suspended inside.

Degree of freedom: The ability to carry out a movement of type translation or rotation, along or around any axis.

Sustainable development: The ability to promote sustainable and innovative performance whilst maintaining an intrinsic balance between the social, economic and environmental activities synonymous with our day-to-day operations.

Renewable energy: Energy that is produced by the effects of the sun and/or the sea and/or the wind.

Crew: A group of more than three people brought aboard for a *race*, which may include a media man [OBR].

Scientific equipment: Multidisciplinary equipment or instruments benefiting the understanding and/or observation of the marine and aquatic environment and which do not assist with the boat's performance.

Foil: A hull appendage primarily used to produce lift and/or affect leeway or stability or elevation or righting moment.

IMOCA: The association that manages WS's International IMOCA 60 Class.

IMOCA 60: IMOCA 60 designates the sailing monohull whose hull length is a maximum of 60 feet and that fits the rules and standards described in the CR.

Yaw: The movement of the boat around a vertical axis that passes through its centre of gravity

LOA: The hull length to which the forward and aft spar overhangs are added.

Hull length: The shortest distance between the two perpendicular planes situated on the centre plane and the flotation waterplane, when the boat is at rest, with zero heel and in lightweight configuration, passing through:

- the aft most point of the **hull**, with its hull appendages,
- and the forward most point of the **hull**.

A pushpit, pulpit, stanchion, antenna mast and its antennae, wind turbine, solar panel and hydro-generator(s) shall not be included in the calculation of the hull length.

Standard mast: A mast with outriggers and standing rigging, as described in appendix C, that are manufactured by an IMOCA chosen suppliers.

Media man [OBR]: A crew member who shall comply with the CR in the same way as every other member of the crew.

Monohull: A boat with one **hull**:

- With a single flotation plane in lightweight configuration or under sail in normal sailing trim, excluding any flotation waterplanes created by hull appendages, the rig, the hydrogenerators and the propulsion system of the "main" engine.
- Of which the hull depth, underneath the widest point of all transverse sections, shall not decrease towards the centre plane of the boat [See D.1[b]].

Number of appendages: It is the number of intersections between a hull appendage and the hull shell that shall determine the number of appendages.

Through-hull fitting: A system that enables the passage through the **hull**, which meets the requirements of the CR.

Hull's plane of symmetry: the vertical XZ centre plane of the boat reference when the boat is at rest, with zero heel and in lightweight configuration.

Working deck: The area inside the perimeter created by the pulpits, stanchions, lifelines and pushpits, where any crew member may stand, rest at, or pass frequently to or by, whilst carrying out the usual manoeuvres necessary when sailing and maintaining the **boat** during when *racing*.

Commercially produced: A fitting, a product or a piece of equipment available to all competitors, at a reasonable market price and within a reasonable timeframe. The **modifications** made to this fitting, product or piece of equipment shall be limited to its normal installation, use or set-up and shall be able to be validated by the CM.

Measurement protocol: A document that lists all procedures and methods used for measuring, calculating and inspecting an *IMOCA 60*.

Keel: The standard keel fin with its bulb that shall be considered as a single hull appendage.

Boat reference: orthonormal X, Y, Z reference in which the boat is positioned at rest, with zero heel and in lightweight configuration. The X axis is the intersection between the hull's plane of symmetry and the flotation waterplane. The X axis originates from the **hull's** aftermost point on the hull's plane of symmetry. The X values increase towards the forward section. The XY plane is horizontal and corresponds to the flotation waterplane.

Rudder: A moveable hull appendage primarily used to affect yaw and shall not be designed to provide vertical lift.

Skipper: The *IMOCA* member responsible for the **boat** when engaged in a *race*.

Standard communication system: Equipment which is manufactured by suppliers selected by *IMOCA* according to specifications referred to in Appendix P.

Standard canting system: A system that controls the standard keel fin, as described in appendix B that is manufactured by an *IMOCA* chosen suppliers.

Transom: The aft most structural element that connects the hull to the deck and/or the cockpit and closes the aft most watertight compartment.

Air draught: The vertical distance between the boat's flotation waterplane and the highest point of the mast at rest, at zero degrees of heel and in lightweight configuration.

Draught: The vertical distance between the boat's flotation waterplane and the lowest point of the boat at rest, at zero degrees of heel, in lightweight configuration.

Cloth: A ply of fibres, unidirectional or otherwise.

Transverse: For a watertight bulkhead to be transverse, it shall be continuous between the starboard side of the hull, the port side of the hull and the deck.

Standard keel fin: A hull appendage, as described in appendix B, to which a single bulb is attached and is primarily used to affect stability and leeway and is manufactured by an *IMOCA* chosen suppliers.

A.3 AUTHORITY

WS has delegated the management of the International *IMOCA 60* Class to *IMOCA*.
IMOCA manages the CR.

A.4 CLASS MANAGEMENT

IMOCA's operating procedures are defined in its Class Regulations which are published annually.

A.5 CLASS MEMBERSHIP

The skipper shall be an active member of *IMOCA*.

A.6 CLASS RULE MODIFICATIONS

- [a] All CR modifications must be approved by vote at an *IMOCA* General Meeting by the IMOCA members.
- [b] RRS Rule 87 is applicable:
« The notice of race or sailing instructions may change a class rule only when the class rules permit the change, or when written permission of the class association for the change is displayed on the official notice board. »
- [c] All modifications to the CR shall be subject to WS's approval.
- [d] Except in matters of extreme urgency, any modification to the rules dealing with stability, the basic structures of the hull, masts, and *hull appendages*, shall be done during the General Meeting that specifically deals with the Class Rules and which takes place after the finish of each Vendée Globe. For the CR specific to *crewed races*, these modifications shall be made at the General Meeting that specifically deals with the Class Rules and which takes place after the finish of the *crewed* Round the World Race.
- [e] If a modification of the Class Rules entails high costs and/or significant technical modification to be made to existing boats, the Grandfather Rule, when described in appendix A, makes existing boats exempt from the requirement to conform to the modified rule.
- [f] If an immediate modification of the CR is required, the *IMOCA*'s Executive Committee may decide how to proceed. This modification shall become permanent following approval of the *IMOCA* members at the next General Meeting.

A.7 CLASS RULE INTERPRETATIONS

A.7.1 CLASS RULES COMMITTEE

- [a] The CRC comprises 3 people nominated by *IMOCA*'s Executive Committee and confirmed by a vote of the members of *IMOCA* at the following General Meeting.
The composition of the CRC is described in appendix F.
It is comprised, when possible, of:
 - A person independent of all *IMOCA* projects,
 - A naval architect not involved in an *IMOCA* project,
 - A WS representative specialised in rules and regulations.
- [b] The CRC's decisions cannot be appealed and cannot be contested by an event jury, including an international jury, nor by any other procedure with any other legal court or tribunal.

A.7.2 INTERPRETATION

- [a] CR interpretations shall be made by *IMOCA* who shall delegate the task to the CRC, who may, at its sole discretion, issue an interpretation.
- [b] Any request for interpretation of the CRs shall be made in writing to the CM, who shall pass it on to the CRC.
- [c] Requests for interpretations may only be made by *IMOCA* members or the CM.
- [d] All interpretations shall be made in writing at the first opportunity and shall be posted on the *IMOCA* website.
- [e] The origin of a request for interpretation shall remain confidential.
- [f] The cost of a request for interpretation shall be set by the *IMOCA*'s Executive Committee.

A.8 BOAT MEASUREMENT CHECKS AND INSPECTIONS

A.8.1 CHIEF MEASUREUR AND MEASUREURS

- [a] The CM is mandated by *IMOCA* to issue or suspend a MC/CMC.

- [b] The decisions of the CM may be subjected to validation by the CRC via a request for interpretation but cannot be appealed and cannot be contested by an event jury, including an international jury, nor by any other legal court or tribunal.
- [c] The CM and other *IMOCA* approved measurers are the only measurers permitted to carry out inspections, checks and measurements required to issue a MC/CMC. Their names and contacts can be found in appendix F.

A.8.2 BOAT INSPECTION

- [a] All procedures, inspections, tests, measurements process and calculations that are required to issue a MC/CMC, are described in the *measurement protocol*.
- [b] The data, measurements, documents and associated information that the CM and measurers gather to generate a MC/CMC shall remain confidential.
- [c] The CM may request a check measurement or inspection to be carried out on any boat at any time.

A.8.3 KEEL INSPECTION

- [a] Before its first launch a *keel* shall be subjected to an NDT.
- [b] A *keel* shall be subjected to an NDT at least once every four years and shall be subjected to an NDT no later than two years before the start of a round the world race.
- [c] A *keel*'s NDT shall cover the entire year for which the boat's MC/CMC is valid and shall be valid for just one round the world race.
- [d] To obtain an MC/CMC the *keel*'s NDT report shall be sent to the CM.

A.8.4 MAST INSPECTIONS

- [a] Before its first use, then every two years and in the year of the start of a round the world race, a mast shall be subjected to an ultrasound control.
- [b] To obtain an MC/CMC the mast's ultra-sound control report shall be sent to the CM.

A.8.5 HULL INSPECTIONS

- [a] To obtain a CMC a hull shall be subjected to an NDT in the year of the start of the *crewed* round the world race.
- [b] To obtain a CMC the hull NDT report shall be sent to the CM.

A.8.6 DAMAGE REPORT

Following structural damage, the *skipper* or his or her designated representative must, within 10 days of the incident, provide the CM with an inspection report covering the damaged section together with details of the circumstances of the damage then, within 60 days, the studies to determine the causes and a report detailing the **modifications** and/or **repairs** made.

A.9 *IMOCA* MEASUREMENT CERTIFICATE

A.9.1 OBTAINING A MC/CMC

- [a] *IMOCA* is the only authority authorised to issue or suspend a MC/CMC.
- [b] The MC/CMC is issued in the name of the **boat** and its *skipper* who shall be an active *IMOCA* member.
- [c] The *skipper* may delegate a representative to assist with the checks, inspections and measurement operations, as well as the administrative steps, required to obtain a MC/CMC. The *skipper* shall remain

the sole person responsible with regard to the CR for the conformity of the boat with the MC/CMC and the *skipper* shall sign the MC/CMC.

- [d] The costs related to the various steps in the process for obtaining a MC/CMC are set by the *IMOCA*'s Executive Committee.
- [e] To be issued with a MC/CMC the **boat** shall be subjected to all checks, tests, measurements and inspections that the CM deems necessary.
- [f] The rules specific to obtaining a CMC are described in the CR. All rules that apply for obtaining an MC also apply for obtaining a CMC except when expressly stated.

A.9.2 MC/CMC VALIDITY

- [a] A MC/CMC is valid to the end of the year of issue unless the CM reduces that period.
- [b] A **boat** shall hold only one valid MC/CMC at a time. A new MC/CMC automatically invalidates the previous MC/CMC.
- [c] A MC/CMC is valid for the duration of a race until its end.
- [d] The CM may declare a MC/CMC invalid at any time.
- [e] In the case of a skipper change the new skipper shall request a renewal of the MC/CMC.
- [f] All **modifications** or **repairs** to the boat require the MC/CMC to be renewed as described in A.9.4.

A.9.3 FIRST MC/CMC

- [a] To obtain the first MC/CMC for a new build the *skipper*, or the *IMOCA* member responsible for the construction of a new boat, shall submit the form in appendix K-2 to the CM before work on the construction of the **hull** commences.
- [b] The CM and/or *IMOCA* measurers shall have unlimited access to the **boat** during the entire construction period.
- [c] The *skipper*, or the *IMOCA* member responsible for the construction of the boat, shall supply the CM with all documents listed in appendix K-3.

A.9.4 MC RENEWAL

To renew a MC/CMC the *skipper* shall submit to the CM the form in appendix K-4, describing any **modifications** or **repairs** carried out on the boat.

A.9.5 RENEWAL OF MC/CMC FOLLOWING BOAT MODIFICATION

- [a] All **modifications** carried out or **repairs** made to the boat following the date of issue of the MC/CMC shall be the subject of a written report, which will be sent to the CM.
- [b] All unreported **modifications** carried out or **repairs** made to the boat render the current MC/CMC invalid.
- [c] The CM shall consider which inspections and specific tests are required to issue a new MC/CMC.

A.10 DOCUMENT STORAGE

IMOCA shall hold all documents that it has used when issuing a currently valid MC/CMC. All documents held by *IMOCA* shall be filed confidentially.

A.11 EXCEPTIONAL CASES

- [a] In the case of an unforeseen event and/or exceptional circumstance making it impossible for the *skipper* to comply with one or more provisions of the CR in order to obtain a MC/CMC, the *skipper* may request an exemption from the application of one or more of such provisions.
- [b] In the event of a request for an exemption from the application of one or more provisions of the CR in order to obtain a MC/CMC the *skipper* shall submit to the CM in writing all details in his possession, along with a written waiver of all claims against the CM. The CM shall submit a report to the *IMOCA* President.
Maintenance of sporting equity as well as the highest safety standards for both crew and boat shall prime.
The CM shall deliver the decision following advice from the *IMOCA's* President.
- [c] Decisions regarding exemptions from the application of one or more provisions set out in these CR for the purposes of being issued a MC are available from the IMOCA secretariat (contact@imoca.org).

Section B – Eligibility

B.1 CLASS RULES AND CERTIFICATION

- [a] Only a skipper in possession of a valid MC/CMC in the name of its **boat** may enter a race. Whilst racing the *skipper* shall at all times comply with the CR.
- [b] In the case of damage during a race, the **boat** may fall out of compliance and still be allowed to finish the race. Non-compliance with the CR may only be due to damage and shall not, under any circumstances, be advantageous to the *skipper*.
- [c] The **boat** shall display all mandated certification marks.

B.2 HULL AND SAIL NUMBERS

- [a] *IMOCA* shall allocate a boat's sail number.
- [b] A hull number issued by the CM shall be moulded or engraved on the boat's *transom*.

CHAPTER II – CONDITIONS AND RESTRICTIONS

Section C – Conditions for racing

C.1 MOVABLE BALLAST

The second sentence of RRS Rule 51 is replaced as follows:

“Any stacking with the aim of altering the trim or stability is permitted within the limits fixed by these rules:

- [a] Food supplies, drinks, non-sealed or otherwise un-attached stores and equipment, when not being used for their primary purposes, may be moved to any position, such that once in place they shall be appropriately attached to the inside of the **hull**.
- [b] Sails not being used shall be either:
 - [i] On a furler, rigged and ready to be deployed,
 - [ii] On the deck inside the *working deck*,
 - [iii] Inside the **hull**.
 Sail bags shall not be watertight.
- [c] Moveable *hull appendages* shall not be moved beyond their normal positions.
- [d] The principal elements of safety equipment described in Article C.3, when not being used for their primary purpose, shall be permanently stowed according to the stowage plan described in Article C.3.1.
- [e] The *skipper* shall only reasonably bring aboard with him what is strictly necessary for the race to be sailed, and under no circumstances shall he bring aboard extra equipment and stores whose sole purpose is to affect the stability of the boat.”

C.2 OUTSIDE HELP, SERVO POWER AND MANOEUVRING

[a] RRS Rule 52 is replaced as follows:

« The boat's standing rigging, running rigging, sails, spars, *foils* or daggerboards shall be adjusted and operated only with the power provided by the crew. Only the keel, the *rudders* and the filling, transferring and emptying of the ballast tanks may be controlled and adjusted by power provided from other sources. »

[b] Servocontrol is expressly forbidden with the following exceptions:

- (i) Adjustment and control of the keel using exclusively the *standard canting system* equipment when supplied;
- (ii) The *rudders* to affect the *yaw*.

[c] The crew's physical force alone shall be used to manoeuvre and trim the boat. This force shall not be accumulated in a storage system, even temporarily, before use.

[d] *When racing*, the *skipper* cannot receive any assistance and/or help from an outside source, including:

- (i) personalised weather assistance,
- (ii) performance assistance,
- (iii) a remote intervention relating to any of the boat's equipment,
- (iv) personalised medical assistance by a person without informing the race's referral doctor,
- (v) organised psychological assistance

C.3 SAFETY EQUIPMENT

All material and equipment described in rules from C.3.1 to C.3.25 inclusive shall be:

- [a] on board,
- [b] of solid construction,
- [c] installed, stayed in place and easily accessible,
- [d] stowed securely,
- [e] functioning correctly and regularly maintained,
- [f] inspected and serviced according to the manufacturers' instructions,
- [g] suitable for the number of crew on board who shall all be instructed in their use.

C.3.1 STOWAGE PLAN

A weatherproof stowage plan shall be provided and shall be displayed near the main companionway hatch, or hatches, where it is most visible, clearly marked with the location of the key items of safety equipment.

C.3.2 DRAINING

- [a] Two buckets of stout construction each fitted with a lanyard, and each with a minimum capacity of 9 litres.
- [b] Two electric bilge pumps, each with a minimum output of 2400 litres/hour. One of these two systems shall be permanently installed and not moved.
- [c] One of the systems mentioned in C.3.2(b) shall enable emptying each watertight compartment from outside of it. The other one must be able to empty each watertight compartment.
- [d] All pumps shall have a minimum rated capacity of 12000 litres/hour and may be combined to meet this requirement.

C.3.3 EMERGENCY DRINKING WATER SUPPLY

[a] An emergency drinking water supply, stored in one or several closed containers must be sealed.

[b] The container(s) shall stay and shall be sealed in place.

[c] The total volume of water shall depend on the duration of the race and the number of crew on board and shall be defined in the Sailing Instructions of each race.

C.3.4 LIFERAFTS

[a] The life rafts shall not be mobile and shall be sealed in place.

[b] The life rafts shall be:

[i] One SOLAS standard life raft:

- This life raft shall be firmly attached and sealed outside, aft of the main companionway hatch (es) and be able to be easily launched.
- This life raft shall be a cannister-type and equipped with a SOLAS Pack A.
- The deficit in equipment between a SOLAS Pack A and B may be contained in an associated grab bag shall be secured with the life raft and shall contain water, food and flares for at least 4 persons with a minimum of: 6 litres of drinking water, 2 kg of high-energy food, 2 parachute flares, 3 hand flares and 3 floating smoke generators.
- This life raft's painter shall be permanently fixed to a strongpoint on the boat in the vicinity of its stowage position.

[ii] One ISO 9650-1-A PACK 2 (<24h) standard life raft.

- This life raft shall be stowed inside.
- This life raft shall be capable of being passed through all watertight bulkheads and hatchways, giving access to the outside, including the transom escape hatch.

[c] To obtain a CMC:

[i] The exterior life raft mentioned in C.3.4(b)(i) shall be replaced with a SOLAS Pack A 8-person life raft.

[ii] The life raft mentioned in C3.4 (b) (ii) shall be replaced with two 4-person ISO 9650-1-A PACK 2 (<24h) standard life rafts and shall be stowed inside the boat, one ahead of the mast and the other close to the emergency exit in the *transom*.

C.3.5 MAN OVERBOARD RECOVERY

[a] Two horseshoe lifebuoys, with the boat's name permanently displayed on their surfaces in proximity to the steering position.

[i] A foam-filled lifebuoy equipped with marine grade reflective material, a sachet of fluorescent water dye marker, a whistle, a self-igniting light and a drogue,

[ii] A lifebuoy equipped with marine grade reflective material, a sachet of fluorescent water dye marker, a whistle, a self-igniting light and a drogue.

[b] A pole with a flag that shall be:

[i] Permanently extended or be capable of being fully extended automatically (e.g. by compressed gas or spring action in less than 20 seconds).

[ii] Attached to a lifebuoy with 3000 mm of floating line.

[iii] So constructed that the flag sits at least 1800 mm off the water.

[c] A life-sling, that shall be strong enough to easily hoist a crew member on board and easily accessible from the cockpit. It shall consist of:

[i] A floating line of at least 36000 mm in length,

[ii] A floating horseshoe that provides at least 90N of flotation.

[d] To obtain a CMC a system similar to the 'Jonbuoy Mark V' with automatic triggering shall be permanently installed at the stern.

C.3.6 LIFEJACKETS

[a] One lifejacket per crew member [to ISO 12402 – 3 (Level 150 N) Standard or equivalent, including EN 396 or UL 1180], that shall be:

- (i) equipped with a whistle and fitted with marine grade retro-reflective material,
 - (ii) compatible with the wearer's safety harness,
 - (iii) equipped with a crotch strap,
 - (iv) clearly marked with the boat's name,
 - (v) have an emergency position indicating light in accordance with either ISO 12402-8 or SOLAS LSA code 2.2.3 Standards,
 - (vi) have a sprayhood in accordance with ISO 12402-8 Standard,
 - (vii) have a PLB unit as mentioned in Article C.3.15 [c], registered with the appropriate authority.
- [b] At least one spare « Rearming kit » for each lifejacket on board, along with a spare activation system for each automatically inflating lifejacket.
- [c] At least one spare lifejacket as described in rule C.3.6[a] without the equipment described in C.3.6[a][vii].

C.3.7 SAFETY HARNESS AND TETHERS

- [a] Each crew member shall have a safety harness and a tether that complies with the ISO 12401 Standard, or equivalent.
- [b] Each harness shall be equipped with a tether of 1000 mm long, with a hook at each end.
- (i) A mid-point hook on a 2000 mm safety line may be used.
 - (ii) All hooks shall be self-closing.
 - (iii) Safety lines shall have a coloured flag embedded in the stitching to indicate overloads. A line that has been overloaded shall be replaced.

C.3.8 PERSONAL EQUIPEMENT

Each member of the crew shall have on board and shall carry as much as possible:

- [a] a sharp knife,
- [b] a waterproof torch,
- [c] a personal AIS beacon,
- [d] on deck at night, a chemical light stick and a personal position light [SOLAS or stroboscopic].

C.3.9 PERSONAL SURVIVAL EQUIPMENT

Each crew member shall have:

- [a] A full set of vacuum-packed warm clothing;
- [b] An immersion suit including head, hands and feet protection that shall:
 - (i) Have an immersed thermal insulation value, without thermal underwear, of at least 0.75 Clo.
 - (ii) Be stowed in a bag attached less than 1500 mm from the main companionway hatch(es).

C.3.10 COCKPIT KNIFE

A strong, sharp knife sheathed and securely restrained and readily accessible from the deck or a cockpit.

C.3.11 SOFT PLUGS

Soft conic plugs of appropriate sizes shall be attached or permanently stowed adjacent to every *through-hull fitting*.

C.3.12 EXTINGUISHERS

a) At least two fire extinguishers of at least 2 kg capacity each suitable for A, B and F rated fires. They shall be easily accessible:

(i) One shall be close to the engine.

(ii) The other close to the companionway [less than 1500 mm from the centre of the companionway hatch(es)].

(b) A fire blanket adjacent to the galley installation.

C.3.13 RESERVED

C.3.14 RADAR

(a) A Pulse Radar with a minimum power of 2 KW or a Broadband-type Radar. The radar antenna/radome shall be situated at a height of at least 5000 mm above the flotation waterplane when the boat is at rest, with zero heel and in *lightweight configuration*.

(b) The radar shall:

- be programmable to automatically scan periodically
- have a remote [external] screen
- have an external alarm

C.3.15 DISTRESS BEACONS

(a) Two portable SARSAT COSPAS distress beacons, certified long-life (minimum 48 hours autonomy), with hydro and manual activation.

These beacons shall not be mobile and shall be:

(i) Dual frequency (406MHz and 121.5MHz) and equipped with a GPS,

(ii) Coded and registered in the name of the boat with the corresponding MMSI number,

(iii) Adequately attached with a line of at least 3000 mm in length whose breaking load shall be at least 1000 kg

(iv) Immediately accessible near to the main companionway hatch(es).

(b) A personal distress beacon (PLB), transmitting on two frequencies (121.5MHz and 406MHz) for each member of the crew.

C.3.16 EMERGENCY TRANSMISSION

At least one *through hull fitting* that is capable of accepting, when the hull is at 180 degrees, the installation of:

(a) A VHF antenna.

(b) A SARSAT-COSPAS antenna, or any other position indicating radio beacon.

(c) An Iridium satellite telephone antenna.

C.3.17 FLOATING ANCHOR/DROGUE

A floating anchor/drogue suitable for an *IMOCA 60* and certified by *IMOCA*.

C.3.18 FIRST AID KIT

(a) The contents of the First Aid Kit shall conform to the recommendations of the on board First Aid Manual. The contents of the First Aid Kit shall reflect the type of race and the size of the crew.

(b) The First Aid Kit shall incorporate the latest edition of one of the following Manuals:

- International Medical Guide for Ships, World Health Organization, Geneva,
- First Aid at Sea, by Douglas Justins and Colin Berry, published by Adlard Coles Nautical - London,
- Le Guide de la Médecine à distance, by Dr J-Y Chauve, published by Distance Assistance BP33 - La Baule Cedex France. An English version is available.
- Skippers' Medical Emergency Handbook, First Aid at Sea, by Dr Briggs and Dr Mackenzie, published by Adlard Coles Nautical - London.
- Another First Aid Manual in the *skipper's* language approved by the CM.

[c] An Emergency First Aid Kit prepared by the *skipper* containing what the *skipper* considers important with which to administer First Aid, shall be securely stowed and easily accessible near the main companionway hatch(es) [less than 1500 mm from the centre of the opening].

C.3.19 DIVING EQUIPMENT

[a] One Spare Air dive tank or equivalent with a minimum volume of 80 litres of air.

[b] A neoprene, full body diving wet suit with gloves flippers and a face mask.

C.3.20 WATERTIGHT EMERGENCY CONTAINER

[a] One emergency watertight container equipped with solid handles and a lanyard with a minimum breaking load of 1000 kg shall:

- [i] be unsinkable;
- [ii] have a minimum of 0.1 m² of fluorescent orange colour on the outside;
- [iii] have the name of the boat permanently marked on the outside;
- [iv] be permanently attached close to the main companionway hatch(es) [no further than 1500 mm from the centre of the opening];

[b] It shall contain at least:

- [i] A handheld, waterproof VHF radio with charged spare batteries.
- [ii] A handheld, waterproof Iridium telephone [or in a waterproof pocket] with charged spare batteries.
- [iii] A handheld, waterproof GPS set with charged spare batteries.
- [iv] A waterproof torch with charged spare batteries.
- [v] A knife.
- [vi] Several Cyalume-type chemical light sticks.
- [vii] Several Fluorescent sea dye markers.
- [viii] An individual SOLAS or stroboscopic light with charged spare batteries for each crew member.
- [ix] 4 red hand flares and 2 orange smoke hand flares conforming to SOLAS LSA Code Chapter III Visual Signals.
- [x] Several energetic foods with a total minimum value of 10000 KJ.
- [xi] A survival blanket for each crew member.

C.3.21 ANCHORS AND TOWING WARPS

[a] Two anchor sets. Each anchor set shall:

- [i] consist of an anchor, a chain and a 50000 mm long, 18 mm diameter pre-stretched polyamide warp, which may be used for both anchoring and towing.
- [ii] be sealed in the same place with its own cable.
- [iii] be able to be readied on deck in less than 3 minutes.

[b] The total weight of the two anchor sets, without their cables, shall be 75 kg minimum.

C.3.22 TORCHES

[a] A high-powered waterproof torch or spotlight capable of being flashed. It shall be rechargeable or shall have charged spare batteries.

[b] Each member of the *crew* shall have a waterproof torch capable of being flashed. Each torch shall be associated with its own charged spare batteries and bulbs.

C.3.23 TOOLS AND SPARE PARTS

Tools and spare parts, including effective means to quickly disconnect the standing rigging from the **hull**.

C.3.24 EMERGENCY TILLER SYSTEM

An emergency tiller system shall be on board from 1st May 2020.

C.3.25 PROTECTION

One helmet to a minimum standard of CE EN 1077 or CE EN 966 or ASTM 2040 or equivalent.

C.4 MEDICAL AND SURVIVAL TRAINING

Training courses are highly recommended for all crew members;

- [a] Before the start of a race the *skipper* (and his *co-skipper* if the race is two-handed) shall have:
- [i] attended a medical training course of the standard required for the race to be sail at least once in the previous five years;
 - [ii] attended a WS approved sea survival course at least once in the previous five years.
- [b] Regular courses that cover, safety, rescue and salvage techniques for *skippers* and *co-skippers* are organised by *IMOCA*. *Skippers* and *co-skippers* shall participate in these courses unless they are in the possession of a written exemption signed by the IMOCA's Executive Committee.

C.5 ADVERTISING

- [a] The *skipper* may display advertising on the boat he is responsible.
- [b] A circle of 3000 mm diameter on each side of the bottom third of the mainsail (above the first reef), or a space to be defined equivalent to a total surface area of 7.0 m², shall be free of all advertising. This space shall be reserved for potential branding associated with the event organiser when in agreement with *IMOCA*.
- [c] The official logo or the *IMOCA* sponsor logo or the *IMOCA* class insignia or the championship logo, shall be displayed back-to-back at the top of the mainsail as well as technical clothing of the skipper and team member on one sleeve.
- [d] Depending on the agreements reached between *IMOCA* and the event organiser, one or more dodgers displaying *IMOCA* and/or event organiser branding shall be attached to the lifelines on both sides of the boat and shall be displayed:
- [i] in port, at the start and at the finish of the race,
 - [ii] under tension on the lifelines towards the stern of the boat.
- [e] The branding scheme is described in appendix E.

C.6 ENERGY / MOTOR

C.6.1 MOTOR / GENERATOR

[a] Overview:

- [i] A motor or a generator shall be:
- Diesel or electric,
 - Permanently installed, protected and to the norms of best practice,
 - Permanently attached to the boat and not moved.
- [ii] A motor or a generator shall not be:
- Used when *racing* to move the boat,
 - Moved inside the boat.
- [iii] All or part of the motor and its propulsion system shall have the ability to be sealed when *racing* such that it shall not propel the **boat**.

- [b] The "main" propulsion unit shall be installed such as to propel the boat and to meet or surpass the following performance standards at all times:
- A traction load of 280 daN at a fixed point for at least 15 minutes,
 - A speed of 5,0 knots in any direction with an autonomy of at least 5 hours,
- These characteristics shall be capable of being checked at the finish of a race.

[c] For a diesel engine or generator:

- [i] The exhaust, cooling and fuel systems shall be permanently installed.
- [ii] All required fuel for a race shall be contained in fixed fuel tanks and not moved.
- [iii] Fuel tanks shall be permanently installed, adequately protected and not moved.
- [iv] Each fuel tank shall have to be closed.

[v] Fuel shall not be transferred between tanks ~~whilst racing~~. The use of a day tank, or header tank, whose volume is less than or equal to 10 litres and which is installed close to the principal motor is exempt from this limitation.

[vi] If used as the “main” propulsion unit the diesel engine shall have a builder’s power rating of at least 35HP and, unless a written exemption is provided by the CM, shall be chosen from one of the four commercial productions listed: Yanmar 3JH5E, Lombardini LDW 1404, Nanni diesel N4.38, Volvo D2-40.

[vii] The standard components associated with the “main” propulsion unit shall not be removed or modified with the exception of the electrical cabling and the alternators, their mountings and pulley systems.

[d] The “main” propulsion unit’s control used for the “forward” and/or the “reverse” [gearbox] shall have to be accessible from the exterior steering position and must be capable of being sealed.

[e] The “main” propulsion unit propeller shall:

- be positioned under the flotation waterplane when the boat is at rest, with zero heel and in lightweight configuration,
- not be retractable,
- not be installed on a hull appendage.

[f] In the case of a diesel engine or a diesel generator on board, a supplementary emergency reserve of 20 litres of fuel shall be stored in a tank sealed in place and shall not be removed.

[g] To obtain a CMC, the supplementary emergency reserve shall be stored in an independent tank permanently connected to the engine and ready for use.

C.6.2 BATTERIES

[a] The batteries shall not be moved when the boat is underway and shall be:

- (i) Waterproof or gel-electrolyte type,
- (ii) Be fixed so that they do not move, regardless of the attitude of the **boat**,
- (iii) Be capable of being sealed in position.

[b] When an electric motor is used to start the “main” propulsion unit, it shall have a separate battery or electrical source with an independent charging system.

[c] No systems using fissile materials for the production or storage of energy, nor acid-based batteries, shall be installed on board.

[d] To obtain a CMC all batteries shall be of commercial production.

C.6.3 FUEL

The only fuels allowed on board are:

- Diesel for a diesel engine, a generator and/or a heating system;
- Gas for cooking and safety equipment.

C.7. NAVIGATION

C.7.1 COMPASS

[a] A “marine” magnetic compass shall be permanently installed, be independent of any electrical supply and correctly adjusted with a deviation card.

[b] An additional compass to that required above shall also be carried on board.

C.7.2 NAVIGATION EQUIPMENT

[a] A 25 W VHF ASN marine radio transceiver, equipped with a fixed antenna.

[b] An active AIS and navigational software which displays AIS targets, equipped with a masthead AIS antenna.

The AIS installation shall be inspected by a competent and reputable organisation/body/company with expertise in the installation of this equipment (Certified Agency or accredited installer).

(i) This organisation/body/company shall check and record the following:

- That the cable and antenna must be of the same impedance;
- That the cable shall not have more than 40% power loss.

(ii) For the purposes of applying for a first MC/CMC this organisation/body/company shall submit to the CM a certificate of conformity, dated less than 12 months previously, whilst an application for a renewed MC/CMC shall be dated less than two years previously.

(iii) To obtain a CMC the AIS shall be Class A or Class B+.

(c) A handheld waterproof VHF radio.

(d) An emergency VHF/AIS antenna.

(e) A Sat Com transceiver.

(f) A GPS.

(g) A “YB3i Tracker” connected on service battery.

(h) An echo-sounder

(i) A speed measuring device.

(j) GMDSS-type equipment for round the world races.

(k) A standard communication system which shall comply with Appendix P.

C.7.3 NAVIGATION DOCUMENTS

Navigation charts for the race area, not solely electronic, light lists, for the geographic zones covered by the race along with chart plotting equipment shall be onboard.

C.8 IDENTIFICATION

(a) To assist with identification at sea the sail number shall be displayed and highly visible on deck.

The minimum dimensions of the characters shall be:

- Height: 900 mm
- Width: 600 mm
- Thickness: 120 mm
- Gap between numbers: 180 mm.

(b) To assist rescue parties in effecting emergency evacuations an area of the hull, which can be easily destroyed, shall be clearly marked out in high visibility contrasting colours on the inside and the outside of the hull.

(c) A bright and highly visible colour shall be applied to:

- The entire surface of the keel,
- The entire surface of the rudders.

And outside on a single area of not less than 2.0 m²:

- on the underside of the hull shell,
- on the deck.

C.9 BOAT: FITOUT AND EQUIPMENT

C.9.1 WORKING DECK

(a) The ISO 15085 – Category A – Man Overboard Prevention and Recovery Standard applies as a minimum and is supplemented by the following specifications as far as C.9.7 inclusive.

(b) The external limit of the working deck shall be situated at least 500 mm inside the projections of the flotation waterplane, with the boat at rest, with zero heel and in lightweight configuration:
- of the sheer line,

- of a straight line passing through the aft most points of the sheer line on each side of the **boat**.

[c] The *measurement protocol* describes the method to establish the sheer line.

C.9.2 PULPITS, PUSHPITS, STANCHIONS AND LIFELINES

[a] General Principles

- (i) The pulpits, pushpits, stanchions and lifelines shall:
 - Make the *working deck* safe in a permanent manner;
 - Have a minimum height above the *working deck* of 600 mm
 - Have a minimum height of 600 mm above the aft-most parts of the pushpits, stanchions and lifelines situated on both sides of the stern of the boat.
- (ii) There shall be a minimum of two lifelines surrounding the *working deck*
- (iii) There shall be no carbon fibre in the pulpits, pushpits and stanchions
- (iv) The CM shall be satisfied that the pulpits, pushpits and lifelines render the *working deck* a safe place for crew members.
- [v] To obtain a CMC the pulpits, pushpits and stanchions shall be fabricated from stainless steel tube with a minimum wall thickness of 1.5 mm. The stanchions shall be of 30 mm minimum diameter and the pushpits and pulpits of 25 mm minimum diameter except for stanchions of a **boat** with a valid CMC dated before 1st January 2020 that shall have a minimum diameter of 28 mm.

[b] Pulpit and pushpit

- (i) The pulpit shall be of tubular one-piece construction.
- (ii) The pulpit shall have at least four attachment points to the deck of the boat.
- (iii) The pulpit shall enclose all forestay anchorages that are on the deck of the boat.
- (iv) Lifelines through stanchions across the stern may replace a pushpit.

[c] Lifelines

- (i) All lifelines shall be:
 - Permanently in place and correctly tensioned,
 - Supported exclusively by the pulpit, pushpits and stanchions at intervals of 2200 mm maximum,
 - Of SK core and cover over their entire length with a minimum diameter of 6 mm.
- (ii) All lashings, links, anchor points and other components that make up the lifelines shall have a breaking load superior to that of the lifeline.
- (iii) The vertical gap between two lifelines shall be less than 380 mm and the gap between the deck and the lower lifeline shall be less than 300 mm.

C.9.3 JACKSTAYS / ATTACHEMENT POINTS

[a] General requirements

Jackstays together with attachment points and harness tethers shall permit:

- A crewmember to clip on before coming on deck from inside the boat and unclip after going below deck,
- A crewmember to move freely between working areas in the cockpit and on deck whilst remaining clipped on, including being able to cross the deck from one side to the other, with the minimum of attachment and detachment operations

Attachment points shall allow two crewmembers to be clipped on simultaneously without depending on the jackstays.

Special care should be taken regarding the use of U-bolts as attachment points as they can lead to accidental opening of some snap hook models.

[b] The jackstays shall be:

- Installed along the deck to port and to starboard of the centre plane and shall not be moved.
- Solidly attached to the deck.
- Of webbing or SK rope with a minimum breaking strain of 20 kN.

[c] Attachment points shall be strong and suitably positioned close to the exterior steering positions(s), the winches, the mast and everywhere members of the crew work for long periods of time.

C.9.4 TOE RAILS

A toe rail with a minimum height of 30 mm shall be permanently installed around the *working deck*, except in the way of fittings and at the base of the *transom*. The toe rail shall be fitted as close as practicable to the vertical axis of the stanchion bases.

C.9.5 HANDHOLDS AND HANDRAILS

[a] The boat shall be equipped with adequate handholds placed inside and on deck to facilitate the safe movement of crew around the boat.

[b] A suitable system of handholds or handrails permanently fixed along the full width of the immersed edge of the *transom* shall be fitted and shall remain permanently in place to aide crew members that have fallen overboard to climb back on board.

C.9.6 NAVIGATION LIGHTS

[a] Navigation lights shall comply with the COLREGs relating to sailing vessels whilst under sail, motoring or at anchor.

[b] Navigation lights for sailing shall:

- be mounted so that they will not be masked by sails or the heel of the boat.
- be mounted above deck level and at least at the height of the lower lifeline

[c] The reserve/auxiliary navigation lights shall:

[i] have the same specifications as the above-mentioned lights,

[ii] be permanently installed and shall not be moved,

[iii] have an independent wiring circuit to that of the primary navigation lights.

[iv] To obtain a CMC, the reserve/auxiliary navigation lights shall be permanently installed in a different position to the primary navigation lights and shall not be moved.

[d] An anchor light shall be permanently installed.

C.9.7 THROUGH HULL FITTINGS, SEA COCKS AND VALVES

Seacocks [quarter turn valves or guillotine valves], watertight valves and their control systems shall be permanently installed on all through hull openings below the waterline when the boat is at rest, with zero heel and in *lightweight configuration*, except in the case of integral deck scuppers, log, sounder and other similar equipment.

C.10 BOAT: LIFE ON BOARD

C.10.1 BUNKS

[a] One or more *bunks* shall be permanently installed on board and not be moved.

[b] The number of *bunks* on board shall be a minimum of half the number of crew on board and rounded up if the number after the comma is greater than or equal to 5.

[c] Each bunk shall be suitable for the height and weight of the crewmembers.

C.10.2 COOKING FACILITIES

A cooking stove installed, accessible and securely fastened with an accessible fuel shut-off control capable of being safely operated in a seaway.

C.10.3 DRINKING WATER

[a] The *skipper* shall be responsible to ensure there is adequate drinking water on board for the duration of the race and the size of the *crew*.

- (b) A desalinator capable of being operated both manually and electrically shall be permanently installed on board. For races of over 5000 nautical miles in length, two desalimators capable of being operated both manually and electrically shall be permanently installed and one of these shall have to stay in place.
- (c) To obtain a CMC, Article C.10.3 [b] is replaced with the following:
 “A minimum of two freshwater tanks, each with a capacity of at least 40 litres and at most 60 litres, shall be symmetrically installed around the hull’s symmetry plane. Freshwater tanks shall not be used for liquids other than drinking water and shall not be filled, emptied or transferred to modify trim or stability. A commercially produced desalinator with a minimal nominal power of 20 litres per hour shall be permanently installed on board and connected to the freshwater tanks.”

C.10.4 TOILET

To obtain a CMC, a boat shall have a permanently installed toilet.

C.11 HYDRAULIC SYSTEMS

No hydraulic systems shall be installed on board a boat except for:

- o The *keel* canting system;
- o The second *degree of freedom foil* adjustment system referred to in E.4 [k];
- o The trim of the headsails tack point, the cunningham and the outhaul.

C.12 IDENTIFICATION ON SAILS

RRS 77 and Appendix G – Identification on Sails is changed as follows:

G.1.1 Identification

The display of letters and numbers on her mainsail, spinnaker and headsail is optional.

This also applies to Offshore Special Regulation 4.01.1.

Section D – Hull

D.1 FUNDAMENTAL RULES

- (a) The **boat** shall be a *monohull* equipped with:
 - (i) a *standard keel fin*,
 - (ii) a *standard canting system*,
 - (iii) one *standard mast*.
- (b) When upright, at rest, with zero heel and in *lightweight configuration* a *boat* shall be symmetrical about its longitudinal centre plane.
- (c) The **boat** shall be designed, built and maintained to compete in OSR Category 0 races.
- (d) With regard to OSR 3.03.1, the boat shall:
 - (i) Be designed, built and maintained to conform with the ISO 12215 Category A Standard, as amended by the ICNN [Institute for Certification and Normalisation in the Nautical Field – icnn.fr] and approved by the convenor of the ISO WG18 Standard, as published on the *IMOCA* website.;
 - (ii) Obtain a certificate of compliance from the ICNN of the *IMOCA 60* construction drawings;
 - (iii) Obtain a signed and dated declaration from the builder that the boat was built in conformity with the ICNN approved drawings.

D.2 DIMENSIONS

- (a) The *hull length* shall be a minimum of 17983 mm and a maximum of 18288 mm [60 feet].
- (b) *LOA* shall be a maximum of 20117 mm [66 feet]. When the rake is modified from 4.0 to 6.0 degrees, it is expressly permitted for the boom to have a 25 mm overhang aft.
- (c) The beam of the **hull** shall not exceed 5850 mm.

[d] The maximum beam of the **hull**, 1000 mm behind the forward most extremity of *hull length*, shall not be greater than 1120 mm.

D.3 HULL MATERIAL LIMITATIONS

The **hull** of the boat, less associated fittings, shall be built according to the following specifications:

[a] The fibres listed below are permitted:

- Hexcel®: IM 7 [6k]; IM2A; IM2C; AS7.
- Mitsubishi Chemical Carbon Fiber and Composites®: MR40; MR60H.
- Toray®: T800H; M30S; T700S.
- Tornel®: T650/42.

All other fibres shall have a nominal modulus of less than 280 Gpa.

[b] Only Nomex® [Aramid Honeycomb Paper]-type and/or foam core materials shall be authorized.

[c] The nominal weight of each adhesive layer or weight of any combination of adhesive layers used to glue Nomex® [Aramid Honeycomb Paper]-type and/or foam core materials, shall be at least 300 g/m².

[d] The nominal weight of each *cloth* shall be at least 150 g/m² and this shall apply to each ply.

[e] Nanotechnologies, nano-sciences and other associated sciences and technologies shall be expressly forbidden in any resin system for any part of the **boat**, with the exception of the **sails**.

[f] To obtain a CMC, the rules D.3 [a], [b], [c], [d] & [e] are replaced with appendix G.

D.4 BUOYANCY VOLUME

[a] The boat shall have a total buoyancy volume greater or equal to 105% of the boat's displacement in *lightweight configuration*.

[b] The *measurement protocol* describes the volume calculation.

D.5 STABILITY AND RIGHTING MOMENT LIMITS

D.5.1 OVERVIEW

[a] *IMOCA*, under the authority of the CM, shall determine the theoretical stability curve for different configurations of the boat in *lightweight configuration* with the measurements taken during the stability tests, information provided by the skipper and measurements taken to verify the different stability criteria described in D.5.2, D.5.3, D.5.4 and D.5.5.

[b] The *measurement protocol* describes the conditions, the methodology, the process used for the different stability tests, the measurements taken and the calculations made.

D.5.2 AVS WORST CASE [AVSwc]

[a] To calculate AVSwc, the boat shall be considered to be in *lightweight configuration*:

- [i] With all ballast tank combinations on the same side filled, including centre line tanks if any,
- [ii] With the *kee*/swung fully to the same side,
- [iii] With all equipment and mobile *hull appendages* in the most unfavourable position,
- [iv] Without the spar's buoyancy.

[b] With the boat in the configuration described in Article D.5.2 [a], the least favourable value of AVSwc shall be greater than or equal to 110 degrees.

D.5.3 STABILITY CURVE AREA RATIO

[a] For the area calculations the *kee* shall be in the centre plane of the boat which shall be in *lightweight configuration*.

- [b] With the boat as described in Article D.5.3 (a), the positive area under the stability area curve shall be at least 5 times greater than the negative area.

D.5.4 MAXIMUM RIGHTING MOMENT

- [a] To calculate the maximum RM the boat shall be in *lightweight configuration* with:
- [i] All ballast tank combinations on the same side filled, including centerline tanks if any,
 - [ii] The *keel* swung fully to the same side,
 - [iii] All equipment and mobile *hull appendages* in the most unfavourable position,
- [b] With the boat in the configuration described in Article D.5.4 (a) the RM shall be less than or equal to 25.5 TM [ton meters] at 25 degrees of heel.

D.5.5 SELF-RIGHTING

[a] For the numerically calculated 180 degrees self-righting test, the **boat** with the *keel* fully canted to one side shall be considered in *lightweight configuration* but without the *standard mast*, standing rigging and the boom.

[b] When in the configuration described in Article D.5.5 (a) the boat shall right itself from 180 degrees of heel.

D.6 WATER BALLAST

- [a] A ballast tank shall only be filled with sea water excluding any other liquid.
- [b] A maximum of 4 ballast tanks may be fitted.
- [c] The ballast tanks shall be installed symmetrically inside the **hull**.
- [d] All associated equipment, plumbing, valves and snorkels shall be permanently installed in the boat and shall not be moved.
- [e] Water shall be able to freely circulate inside each ballast tank and shall be able to reach the lowest point of the tank.
- [f] Each ballast tank shall have a removable inspection hatch to reach the lowest point of the tank.

D.7 COCKPITS

- [a] The ISO 11812 Standard shall apply [Watertight cockpits, quick-draining cockpits, design category A].
- [b] A semi-permanent washboard is allowed but shall conform to Article 8.2.4 [Other requirements] of ISO 11812 Standard, and it shall only open outwards.

D.8 WATERTIGHT COMPARTMENTS

For the application of Articles D.8 and D.9, refer to the report authored by Bureau Veritas, outlining the pressure generated by the sloshing of liquid inside a compartment.
This report is available from the *IMOCA* secretariat (contact@imoca.org).

D.8.1 WATERTIGHT BULKHEADS

- [a] The required watertight bulkheads shall be built in a way to be capable of resisting a head of water on the other side without any leakage.
- [b] A watertight bulkhead shall be *transverse*.
- [c] There shall be 5 watertight bulkheads making six separate watertight compartments.

(d) No two watertight bulkheads shall be separated by more than 5000 mm.

(e) The forwardmost watertight bulkhead shall be less than 2740 mm behind the forwardmost point of the hull whilst the boat is at rest, with zero heel and in *lightweight configuration*.

D.8.2 WATERTIGHT BULKHEAD DOORS

(a) The boat shall be capable of being inspected from bow to stern by passing through the watertight bulkhead doors.

(b) The watertight bulkhead doors, if they are not permanently installed, shall be stowed as close as possible to their associated opening and shall be easily put in place to quickly make the bulkhead watertight.

(c) The watertight bulkhead doors and their locking systems shall be capable of withstanding the pressure generated by the water in the adjacent flooded compartment.

D.8.3 CRASH BOX

A crash box, made of closed-cell foam, capable of being destroyed without affecting the watertight integrity of the hull should the boat make a head-on collision, shall be fitted in the bow of the boat.

D.9 HATCHES AND EMERGENCY EXITS

D.9.1 EMERGENCY EXITS

(a) The boat shall have at least two emergency exits:

(i) With a minimum opening of 0.2 m² and of a geometry allowing the interior life raft and the crew in survival suits to pass through;

(ii) That are equipped with a solid and watertight closing mechanism with handles on the inside and the outside that control the locking mechanism, if there is one;

(iii) That are capable of resisting the pressure of the water regardless of the sea conditions and the attitude of the boat.

(b) At least one emergency exit shall be forward of the mast.

(c) At least one emergency exit shall be within 500 mm of the aft most point of the hull.

This emergency exit shall be above the flotation waterplane, with the boat at rest, in *lightweight configuration* so that the crew can pass through it in both directions when the boat's heel angle is anywhere between 0 and 180 degrees.

D.9.2 COMPANIONWAY HATCH

The main companionway hatch(es) shall be equipped with a solid and watertight closing system, capable of being operated by one person on the inside and the outside, including when the boat is upside-down.

D.9.3 HATCHES

(a) No hatches shall open towards the interior of the hull (except portholes with an opening less than or equal to 0.071 m²).

(b) Hatches shall be positioned such that they shall always be above the flotation waterplane when the hull has a heel angle of 90 degrees. They shall be permanently installed, capable of being closed quickly and remain closed regardless of the sea conditions or the attitude of the boat.

(c) Hatches, their locking systems and associated equipment, shall remain watertight and resist the pressure of water when the boat is inverted.

Section E – Hull Appendages

E.1 OVERVIEW

- [a] Any appendage on the hull shall be a hull appendage and shall be either: a keel, a rudder or a foil.
- [b] There shall be no more than 5 hull appendages.
- [c] A hull appendage shall not present volumetric and dimensional characteristics that could allow it to be considered a hull.
- [d] Allowing for exceptions for the application of rule E.4[k], no combined movement [helical, etc.] shall be displayed by any hull appendage.
- [e] Flaps and deformable surfaces shall be expressly forbidden on hull appendages. Hull appendage deformations due to operational loading and on which no control can be exerted are exempt from the above sentence.
- [f] The foil cases shall not open into the hull, with the exception of the inspection watertight hatches, whose openings are completely above the flotation waterplane of the boat, when at rest, with zero heel and in lightweight configuration.
- [g] Materials whose specific density is greater than 11.4 shall be expressly forbidden in any hull appendage.
- [h] The draught shall not exceed 4500 mm when the boat is at rest, with zero heel and in lightweight configuration.
- [i] All hull appendages shall have an identification mark placed on them by the CM and the hull appendages, other than the keel, shall conform to appendix G.

E.2 KEEL

- [a] The standard keel fin and standard canting system shall conform to appendix B. They shall not be modified except in way of the bulb to keel joint and the keel fin root fairing, both may be locally modified.
- [b] All links, fixings and connections joining the different elements of the standard keel fin to the standard canting system shall be made in accordance with appendix B.
- [c] The longitudinal angle of the rotational axis of the keel shall be between 4.0 and 9.0 degrees with respect to the flotation waterplane of the boat, at rest, with zero heel and in lightweight configuration.
- [d] The keel shall have only one degree of freedom.
- [e] The lateral angle the keel may rotate around its axis of rotation shall be a maximum of 38 degrees on each side.
Appropriate mechanical stops shall be sealed in place on each side to limit the mobility of the keel to the stability calculations' maximum permitted angle. Proof [drawings, measurements and photos taken by the measurer before the final assembly of the ram] that a mechanical stop has been placed in the base of the ram, shall be provided. A hydraulic and/or electrical stop shall not be accepted.
- [f] The keel shall be able to be:
 - [i] manually operated from inside, regardless of the attitude of the boat;
 - [ii] locked in the centre plane with the safety system supplied with the standard canting system.
- [g] For technical reasons associated with the correct functioning of the keel the definition of a monohull can be waived in the zone surrounding the hull-to-keel junction. This zone is limited in width to 500 mm overall and to a depth of 40 mm above the projected fair surface of the hull shell on the centre line, extended if necessary, as described in the diagram below.

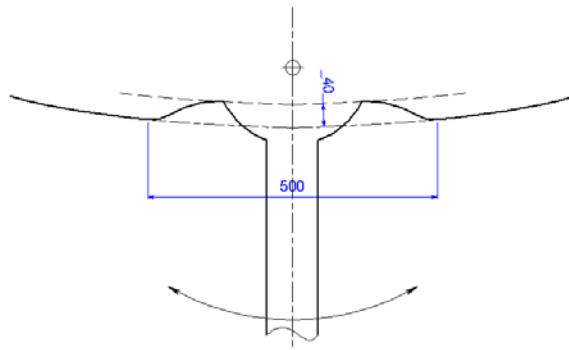

- (h) To safely use this equipment the skipper shall follow the standard keel fin and standard canting system instructions that are included in Note 1 supplied by the manufacturers on delivery of the components.
- (i) The keel shall not be equipped with appendages or any other system that could affect the suspension and/or the righting moment, leeway, directional stability or elevation.

E.3 BULB

- (a) The **boat** shall have one bulb attached to the standard keel fin. The bulb shall conform to appendix B.
- (b) The penetration of the standard keel fin into the bulb shall conform with appendix B.
The centre of gravity of the bulb shall be ahead of the torsional axis of the standard keel fin.
The bolts used to attach the bulb to the standard keel fin shall be of high tensile stainless steel 17.4PH or equivalent.
- (c) The weight of the bulb shall not exceed 3000 kg.
- (d) To obtain a CMC, the weight of the bulb shall not be less than 2450 kg.

E.4 FOIL

- (a) There must be 2 foils.
- (b) The foil must be a solid structural unit; its geometry must be a single, continuous surface at every point. The foil section must be a continuous closed contour less the fittings associated with the degrees of freedom. All or part of a foil of a T and/or Y shape and/or similar is expressly prohibited.
- (c) A foil shall adhere to the following maximum limits:
 - (i) a static moment of 8.00 m³,
 - (ii) a total developed surface area of 7.70 m²,
- (d) No point of each foil shall exceed 5750 mm on either side of the hull's symmetry plane when the two foils are retracted symmetrically.
- (e) The Y value of the centroid of each foil section shall not decrease from the hull's plane of symmetry to the end of the foil when the latter is fully extended. It is expressly permitted for the centroid values of this foil's end sections to decrease from a single series of normal foil sections within a maximum Y limit of 105 mm and a maximum Z limit of 210 mm and this shall be the case whatever the second degree of freedom, if it exists.
- (f) It is expressly permitted to attach one or several fixed fences on each foil to avoid a local ventilation phenomenon.
This type of fence shall:
 - (i) be non-mobile in relation to the foil,
 - (ii) be attached to the perpendicular section of the foil,
 - (iii) measure less than 50 mm wide on each side of the foil blade.
- (g) A foil must pass just once through the hull shell. The intersection between the foil and the hull shell shall be above the flotation waterplane when the boat is at rest, with zero heel and in lightweight configuration.

[h] A foil shall be able to retract into and extend out of the hull shell and shall use only one degree of freedom for this movement. The section of foil which retracts into and extends out of the hull shell shall have normal constant sections.

[i] It is expressly permitted for a foil to have a second degree of freedom. If it exists, this degree of freedom shall be a rotation of the foil, which shall be limited to an angle of 5.0 degrees.

[j] No device shall be used to induce distortion of the foil. Solely distortion generated by hydrodynamic forces and those generated by systems associated with the movement(s) of the foil in E.4 are expressly permitted.

[k] Grounding: In the event that the foil suffers significant impact, it must be demonstrated to the CM that its installation enables the integrity of the watertight compartment around the foil casing to be retained.

[l] The characteristics of the associated foil system must be validated with the CM prior to its implementation on the boat.

[m] In general, the measurement protocol details how to check the conformity of the foils' characteristics and their installation in the boat to check the whole set-up complies with the CR.

E.5 RUDDER

[a] The number of rudders shall be two.

[b] The « fully lowered » position of the rudder shall be its « normal use » position.

[c] When in the « fully lowered » position the entire rudder shall fall within the limits of the hull length.

[d] In all cases where the rudder is stable and fixed in a position other than the « fully lowered » position the CM must be satisfied that the rudder has no effect on the flow of water on and near the hull shell.

[e] The rudder's attachment points to the **hull** shall be fixed and shall not be moved.

[f] All points along the leading and trailing edges of the rudder shall be in the same plane.

[g] Below the hull shell, a fence may be fitted on each rudder to avoid local ventilation. This type of fence shall be:

[i] Non-adjustable with respect to the rudder,

[ii] Perpendicular to the rudder's axis of rotation in the transverse plane,

[iii] Attached no more than 200 mm below the hull shell when the rudder is “fully lowered” position,

[iv] No wider than 30 mm on each side of the rudder.

Section F – Rig

F.1 STANDARD MAST

[a] The standard mast shall:

[i] Conform to appendix C,

[ii] Hold an IMOCA certificate of conformity,

[iii] Be weighed in the configuration defined by the CM and, if necessary, have corrector weights added.

[b] To use the standard mast safely the skipper shall follow the instruction manual for stepping and use of the standard mast that are described in Note 2 provided by the builder at delivery.

[c] The standard mast shall not be **modified** (cosmetic or structural **modifications**) except for **modifications** that can be defined as 'running rigging and non-essential fittings related to the primary purpose of the mast' and **modifications** permitted in appendix C.

[d] All **repairs** shall be made following the CM's approval and under his control.

F.2 AIR DRAUGHT AND MAST

[a] The air draught shall not exceed 29000 mm when the boat is at rest, with zero heel and in *lightweight configuration*.

[b] Whilst racing the mast rake shall not be adjustable. It will be measured when the boat is at rest, with zero heel and in *lightweight configuration* and shall be between 2.0 and 6.0 degrees.

[c] An inclined mast is expressly forbidden and the mast shall never be inclined on windward from the centre plane of the *boat*.

[d] The shrouds and tie-rods shall never be disconnected nor adjusted when underway at sea.

F.3 STANDING RIGGING

[a] The standing rigging shall conform to appendix C.

[b] The Forestay 2 shall not be removable nor adjustable when racing.

F.4 OUTRIGGERS

RRS 50.3 is modified as follows:

[a] The outriggers supplied with the *standard mast* shall be used solely for holding up the rig and sail trim.

[b] Other outriggers may be used solely to assist with sail trim, either to *windward* or to *leeward*." These outriggers can be stowed on deck and, where this is the case, astern of the aftermost point considered to determine *LOA*.

Section G - Sails

G.1 OVERVIEW

[a] The number of sails on board shall be at most 8.

[b] A sail shall never be positioned:

- (i) above the highest point of the mast,
- (ii) ahead of the forward extremity of LOA,
- (iii) behind of the aft most point of LOA [See Article D.2(a) and (b)].

G.2 RESERVED

G.3 HEADSAILS

[a] A 'storm jib' headsail, with a surface area of between 14 and 25 m², made of a heavyweight *cloth* and of a high visibility colour shall be on board and shall be capable of being safely set in heavy weather conditions.

[b] Whilst *racing*, the J2 shall be permanently attached to the Forestay 2.

[c] To obtain a CMC:

- (i) Headsails shall be furled when they are not in use, except for spinnaker-type sails (with a half width greater than or equal to 75% of the foot length).
- (ii) Inflatable battens, luffs and other inflation systems shall be expressly forbidden in headsails.
- (iii) Headsails with a surface greater than 180 m² shall have no battens.

G.4 IDENTIFICATION

All sails on board shall be stamped by the CM as specified in appendix N.

To obtain a CMC, carbon fibre shall not be used in sails.

CHAPTER III – APPENDICES TO THE CLASS RULES

Appendix A: Grandfather Rules

The rules described in Chapters I & II relating to equipment manufactured by suppliers chosen by *IMOCA* solely apply to *IMOCA 60s* fitted with this equipment.

AA.1 Overview

Rules AA.1.3 to AA.8 do not apply to a boat that has received its first MC after 1st January 2015.

Rules AA.10 and the subsequent rules do not apply to a boat that has received its first MC after 15 April 2021 unless the start date for its new build declaration is earlier.

AA.1.1 Boats benefitting from a grandfather rule shall not make **modifications** that go against the intention of any new rules.

AA.1.2 For a boat that has not had a MC renewed for four or more years the *skipper*, or the designated representative, shall prepare a thorough survey report, close to the date of the request for a MC renewal.

This report shall be:

- prepared by a recognised qualified surveyor and carried out in good faith using all appropriate methods;
- submitted to the CM.

The CM will decline to accept such a report if the CM judges the report incomplete or carried out by a surveyor without the level of competence required.

AA.1.3 When carrying out a 180-degree self-righting test the boat with the keel fully canted to one side shall be in *lightweight configuration* but without: the mast, standing rigging and the boom. The self-righting test shall be carried out digitally in such a configuration and the boat shall right itself from 180 degrees of heel.

AA.1.4 The swing keel shall conform with Article E.2(f)(i).

AA.1.5 Appropriate mechanical stops shall be sealed in place on each side to limit the mobility of the keel to the maximum angle permitted by the 10-degree test or the angle imposed by the CM.

In the case of a stop in the base of the ram, proof (drawings, measurements and photos taken by the measurer before the final assembly of the ram) shall be provided before the 10° test is carried out.

AA.1.6 For boats with just one hydraulic ram to cant the keel, an appropriate locking mechanism shall be permanently installed to hold the keel in the centre plane of the boat. This solution must be of a solid and rigid nature mechanically linking the keel head to the **hull**. A double ram system shall be considered as a locking system.

AA.1.7 For boats building a new keel

(a) Design rules

The keel fin shall be made of a single forged steel piece conforming to the design rules described in appendix A-1.

(b) Fitting the keel to the boat

The keel shall be fitted using best practice. The fitting of the keel and the associated canting system remain the sole responsibility of the owner, who should take note of the information at his disposal described in appendix A-1.

(c) Design Calculations (DC)

A certificate of conformity of the keel to the design rules and a report describing the design process and structural calculations made shall be delivered to the CM.

It shall include:

- The structural calculations for the various components of the keel and its attachment for the differing load cases along with the safety margins included.

- The mechanical properties of the materials used.
- The frequency calculations of the *keel* in bending and torsion.
- The position of the CG of the bulb and the torsional axis.
- And all other elements that may facilitate conformity with appendix A-1.

AA.1.8 Keel testing

- [a]** An NDT test, defined by the CM, shall be carried out for all keels except those described in appendix A-1 or B. The NDT shall cover the entire duration of the validity of the MC and shall have a validity of no more than 2 years, which is only valid for one round the world race.
- [b]** The NDT report shall be delivered to the CM.

AA.1.9 If one of the fundamental components of the keel was built after 1st July 2009 the entire keel shall be considered to have been built from that date.

AA.1.10 Keels built before 1st March 2013 shall respect the 2012 CR and their appendices.

AA.1.11 For boats that received a MC before 1st May 2013, the elastic limit [RP at 0.2%] used in the design calculations shall be a maximum of 800Mpa.

AA.1.12 Mast materials

- [a]** The fibre specification certificates delivered with the fibres used in the manufacture of non-standard masts shall be filed by the teams and remain available for the CM to inspect at any time.
- [b]** Permitted fibres for the manufacture of a non-standard masts are limited in value to the longitudinal modulus.
- [c]** M40J, M46J, HS40, HM54 and HM63 [Industrial] fibres are permitted and define this upper limit.
- [d]** The target average value of the M46J fibre is 436 GPa, measured using the ASTM D4018 Standard method.
- [e]** The target average value of the HS40 fibre is 455 GPa, measured using the JISR 7601 method.
- [f]** The target average value of the HM63 [Industrial] fibre is 435 GPa, measured using the SRM 16R_94 [similar to ASTM D4018] method.
- [g]** All fibres whose target average longitudinal modulus exceeds those of either M46J or HS40 shall be expressly forbidden.

AA.1.13 Rigging

- [a]** The forestays, backstays, runners, permanent or temporary, shall be attached inside the lateral limits of the sheer line, and the longitudinal limits behind the forward most point of hull and ahead of the aftermost limits of the port and starboard sheer lines.
- [b]** There shall be one structural fixed forestay, non-removable and non-adjustable, whose intersection with the forward face of the mast shall be in the upper third of the mast.

AA.1.14 Boom

- [a]** The gooseneck shall be on the deck or equipped with an easily removable pin in the case of a dismasting.
- [b]** In the case of a boat unable to conform to AA.1.14 [a] a 6000 mm long tube (or 2x 3000 mm sections able to be sleeved) shall be on board capable of being used to make a jury rig in the event of a dismasting.

AA.1.15 Modification of an existing boat

- [a]** An existing boat whose hull shell has been modified, including below the sheer line [bottom+upperworks] over an area of 50% or more shall be considered as a boat receiving its first MC after 15 October 2020.
- [b]** It shall satisfy all class rules applicable to a new boat.
- [c]** The date on the first MC issued to this boat will define the initial shape of the hull to be considered.
- [d]** Cumulative modifications over time shall not exceed the limit of 50%.
- [e]** An existing boat shall not increase her maximum beam more than the value mentioned on the last issued MC before modification except if the maximum beam of the hull was less than 5.85 metres.

AA.1.16 Pushpits, pulpits and lifelines

- [a]** The pulpit may be in two parts and open on condition that the pulpit and any part of the boat [a fixed forestay is a part of the boat, removable forestays are not considered part of the boat] shall not be larger than 360mm.

- (b) The two parts of the pulpit shall not be bridged with a SK covered and cored rope when the two parts pulpit is open and that the opening between the pulpit and any part of the boat is greater than 360mm.
- (c) One break in the continuity of the lifelines on each side of the boat of 500 mm maximum length, measured normal to the lifeline, may exist on condition that an overlap of at least the same length as the opening exists.

AA.1.17 Exceptions to obtain a MC

Rules D.1[d]; D.2(c) & [d]; D.6[b]; E.2(f)(ii); E.3[b]; E.4(b)&(c)&(d)&(e)&(k); F.2[b]; F.3[a] and F.4[a] shall not apply and also:

- o D.3 for a boat having received a first MC before 1st May 2013;
- o D.5.2[b] for a boat having received a first MC before 1st July 2009;
- o F.2[a] for a boat having received a first certificate before 1st July 2009.

AA.2 Boat ready to sail whit first launch date was before 1st January 2006

Materials with a specific density greater than 11.4 [keel and/or bulb] shall not be used if the bulb is changed.

AA.3 Boat issued first MC before 1st July 2009

AA.3.1 Any material may be used for the manufacture of the mast.

AA.3.2 A boat may not have the already approved hollows in its hull increased in depth.

AA.3.3 Article E.1[b] shall not apply and the number of *hull appendages* is unlimited except in the case where a daggerboard-type appendage is changed to a *foil*-type appendage.

AA.3.4 For all boats with an *air draught* greater than 29000 mm, no modifications shall be made to the mast that increases the *air draught*.

AA.3.5 For all boats with an *air draught* less than 28000 mm, no modifications shall be made to the mast that increases the *air draught* to greater than 29000 mm.

AA.3.6 *LOA* and *hull length* shall conform to Article D.2[a] and [b].

To be excluded from consideration within the *hull length*, a *hull appendage* [such as a *rudder*] shall have no plane elements beyond the limit of *LOA* intended to artificially extend the waterline length with a surface area greater than 0.12 m².

AA.3.7 The AVSwc shall be greater than 108 degrees.

AA.3.8 For all boats with an AVSwc less than 110 degrees, all modifications taken together shall not contribute to reduce the AVSwc.

AA.3.9 No modifications shall be made that increases the RM of the boat whose RM is greater than 32TM [Tonne meter].

AA.3.10 No modifications shall be made that increase the RM above 32 TM for boats that have a RM below 32 TM [Tonne meter].

AA.3.11 A watertight bulkhead may terminate on a ballast tank, a hull appendage case or any other element of the hull.

AA.4 Boat issued with a MC after 1st July 2009 and before 1 May 2013

AA.4.1 The maximum RM [with all tanks on the same side filled, including central tanks if they exist and mobile equipment stacked to the extreme on the same side and with the *keel* swung fully to the same side] shall be less than or equal to 32 TM.

AA.4.2 For a boat having received a first MC after 1st July 2009, AVSwc shall have to be greater than or equal to 110 degrees.

AA.5 Boat issued with a MC before 1st May 2013.

AA.5.1 A boat intending to benefit from the rules specific to boats issued with their first MC after 1st May 2013:

- [a] Shall be equipped with an appendix A-1 keel fin, or an appendix B *standard keel fin*, or shall have a cast iron keel built before 1st May 2013.
- [b] May benefit from the Grandfather Rule with regard to hull materials and BMAX,
- [c] May keep its original mast or use another non-standard mast,
- [d] Shall conform with D.5.2, D.5.3, D.5.4 and D.6,
- [e] May disregard Appendices AA.5.6 and AA.5.7.

AA.5.2 A boat may use a non-standard mast. In the case of a change of mast the new mast may keep the same static moment as the previous mast or if the static moment is reduced it shall be greater than the static moment produced with a *standard mast*.

AA.5.3 In the case of a modification to the **hull** a boat shall conform to Article D.3. Should it be impossible to conform to Article D.3.2 and before any modifications are made to the **hull**, approval from the CM shall be sought for the use of materials suitable for that **hull**.

AA.5.4 Reserved.

AA.5.5 Excluding associated fit-out and corrector weights, hulls may be built without conforming to Article D.3.

AA.5.6 For initial angles of heel:

- [a] with all mobile weight moved to the most extreme position and with all ballast tanks filled in the most unfavourable configuration the boat shall not heel beyond 10 degrees from the vertical.
- [b] Each ballast tank shall be filled or emptied in turn in the search to determine the most unfavourable configuration.

AA.5.7 For the angle of vanishing stability [AVS]:

- [a] This angle shall be greater than 127.5 degrees.
- [b] This angle shall be determined from the theoretical stability curve of the boat with information/data gathered from the stability tests and from the designer/architect.
- [c] The buoyancy of the spars shall not be considered in these calculations.

AA.6 Boat issued with a MC after 1st May 2013 and before 1st May 2015

AA.6.1 Rules governing the manufacture of appendix A-1 keels

- [a] The keel manufacturer shall provide the CM with a certificate of materials used.
- [b] The materials shall be delivered with their compliance certificates.
- [c] All areas shall be easily inspected by hand and in plain sight.

AA.7 Boat issued with first MC after 1st May 2013.

The maximum beam of the forward section of the hull, measured 1000 mm behind the forward most point of the hull used for the determination of *hull Length*, shall not be wider than 1120 mm.

AA.8 To obtain a CMC

AA.8.1 The boat shall have a *standard keel fin* as described in appendix A-1 or appendix B and a *standard mast*.

AA.8.2 Exceptions: Rules D.1[d]; D.3[b]; E.5[c]; F.2[a]; AA.1.8[a]; AA.1.10; AA.1.12; AA.1.13; AA.1.14; AA.1.16; AA.1.17; AA.3.1; AA.3.3; AA.3.5; AA.3.10; AA.5.1[a] & [c] & [d]; AA.5.2 and AC.2.2[a] shall not apply.

AA.9 Dimensions

Rule D.2[b] only applies to boats equipped with a *standard mast*.

AA.10 Rule E.4

It is expressly forbidden to replace a *foil*, which does not conform to rule E.4 with a new *foil* built in identical fashion.

AA.11 Foil measured before 15 October 2020

AA.11.1 The rules E.4(b)&(c)&(d)&(e) do not apply.

AA.11.2 To use a *foil*, which does not conform to E.4(c), the boat at rest, with zero heel and in *lightweight configuration* shall have a mast rake of between 2.0 and 4.0 degrees and the *foil's* second *degree of freedom* shall be limited to 3.0 degrees.

AA.11.3 To be expressly permitted, the *foil*, its geometric shape, its penetration into the boat and the associated systems shall not be modified. The shape of the *foil*, its penetration and the associated systems shall remain identical, except with a view to adhering to E.4(c)(i).

Appendix A-1: Non-standard keel design

The keel fin shall involve a single casting. It shall have no welds of glued elements in its structure.

Keel fin materials:

Forged stainless steel whose minimum requirements are:

Minimum resilience = 85 J

0.2% elastic limit: minimum of 800Mpa

Minimum elongation: 12%

The following materials, which conform to the requirements listed above, may be used:

- VG900i from "Thyssen"
- APX4 from "Aubert et Duval"
- And any material, which has been subject to prior written approval of the CM.

Geometric constraints:

Cavities are permitted under the following conditions:

- The maximum width of a cavity shall be 30 mm.
- The maximum depth of a cavity in mm shall not exceed twice the width of the cavity plus 90 mm
- Cavities shall be filled with material whose density is less than 7800kg/m³.
- No structural hatch shall be used to cover-up a cavity
- The maximum depth of a cavity shall not exceed 210 mm (for a cavity 60 mm wide or more)
- Hydrodynamic and non-structural fairings shall be able to be dismantled for inspection

Dimensioning convention:

The XYZ reference is that of the boat

The attachment points correspond with the load zones and number three in total:

- Keel head axis zone.
- Keel rotation axis zone.
- Bulb to keel fin attachment zone.

The keel head insert into the hull shall be of 450 mm minimum.

Case 1

Keel horizontal, 1g on the *keel*. Reaction at the keel head locked off with the angles and *degrees of freedom* relevant to the keel ram.

- Coefficient of 5 RP 0.2 minimum across the whole keel.
- Coefficient of 6.5 RP 0.2 minimum on the attachment points.

Case 2

- Grounding: *Keel* vertical: apply 27 Tonnes to the forward tip of the bulb in the X axis.
- Coefficient of 1 minimum for the breaking strain of the material.
- Check that the elastic limit of the keel bearings and attachment points is not exceeded.
- Combined lateral and longitudinal case: *Keel* horizontal Reaction at the keel head locked off with the angles and *degrees of freedom* relevant to the keel ram and emergency keel ram (chose the most unfavourable case).

The following shall be applied: [Gravity Z*2,5 + Gravity X] * 2;

Gravity shall be applied towards the bow of the boat and then to the stern of the boat.

- Coefficient of 1 minimum with RP 0.2.

NOTE: The required criteria is a globally elastic behaviour, with the absence of residual deformation [of the residual deflection type on the keel fin] after the load application. The overruns of local elastic limits [in a fillet for example] are acceptable.

Natural keel frequencies:

With the keel fitted to the boat, rotational axis fitted and fixed, the hydraulic system attached and fixed in the centre plane, the keel's frequency shall be equal to or greater than:

- A- 3.4Hz in torsion [Rot Z]
- B- 1.1Hz in lateral bend [Rot X]
- C- 4 Hz in longitudinal bend [Rot Y]
- Ratio of a/b >2.7

Calculation methods:

Finite element calculations volume control type – linear domain with justification:

Recommended Tetra 6 grid: 10mm globally down to 2mm locally in fillets and attachment points

Locking: Bearing type for the rotation axis and the keel head;

Aft bearing locked in Fx + Fy + Fz;

Forward bearing locked in Fy + Fz;

Keel head locked to represent the angular components of the ram forces.

Documents to be supplied to the CM:

Grid view

Lateral Deflection @ 1.g with the keel horizontal

Mode deflections and natural frequencies

Overview - Von Mises Stresses

Overview: Principal Stresses

Local view for high load zones and attachment points.

XZ plan view @ Centre line: Von Mises

Horizontal view at the bearings

Horizontal view at the keel head

Horizontal view at the bulb attachment point

Horizontal view at the half-height level of the keel.

Horizontal view at the 200mm level above the bearings

Modifications:

No modifications shall be made to the keel or part of the keel without a full structural analysis being resubmitted to the CM.

Appendix B: Standard keel and standard canting system

Appendix B-1: Standard keel fin

The *standard keel fin* is supplied by AMPM.

AB-1.1 ASSOCIATED PLANS AND DOCUMENTS

The following plans and documents are associated with appendix B.

They should be consulted with the most up to date versions of the following drawings and plans:

- 0669_IMOCA_HDS_Quille monotype_Principe de montage Axe Verin_20141002
 - [One Design Keel Ram pin assembly principles-2014]
- 0669-1000 - Quille IMOCA - IND H - Geometrie generale - Annexe B-2013
 - [IMOCA Keel – General geometry – Appendix B-2013]
- 0669-1310 - Quille IMOCA - IND B - Assemblages Composite
 - [IMOCA Keel – Composite assemblies]
- 0669-1410 - Quille IMOCA - IND E - Principes assemblages metal – Bulbe
 - [IMOCA Keel – metal-bulb assembly principles]
- 0669-1420 - Quille IMOCA - IND D - Assemblages metal - Axe verin
 - [IMOCA Keel – metal - ram axis assembly]
- Plan de détail palier vérin
 - [Ram bearing details]
- Plan des entraxes 2/ assemblage verin bras
 - [Ram piston assembly]

AB-1.2 DESCRIPTION

The supply consists of:

- The standard keel fin, finished and equipped with its fairings and ready to paint.
- The ram pin.

The supply does not include:

- The keel rotation bearings;
- The bushings and locking pins and all elements required to attach the standard keel fin to the bulb;
- The bulb;
- The olive [standard keel fin fairing in way of the transition through the hull];
- Screws, fixings and /or all elements required to attach all standard parts together;
- All components related to the watertight integrity of the entire system [Baffles, cable glands...].

The standard keel fin shall be issued with an IMOCA approval which gives it a serial number and it must be supplied with a certificate of conformity. The approved supplier shall provide a delivery receipt approved by the client on delivery.

AB-1.3 INSTALLATION

The theoretical static loads that must be supported are:

	Static Load	Safety Margin	Supplier	Working Load	Static Load [SM = 1] Grounding
On the forward keel bearing	27.8 T	6.5	TEAM	180,7 T	144 T
On the aft keel bearing	13.1 T	6.5	TEAM	85,2 T	147 T
On the keel head axis	37.6 T	4	STANDARD	150,4 T	-
On the principal ram bearing	37.6 T	3	STANDARD	112,8 T	-
On the safety ram bearing	31.0 T	3	STANDARD	93 T	-

AB-1.4 BULB WEIGHT / INERTIA

The bulb shall conform to the following limits:

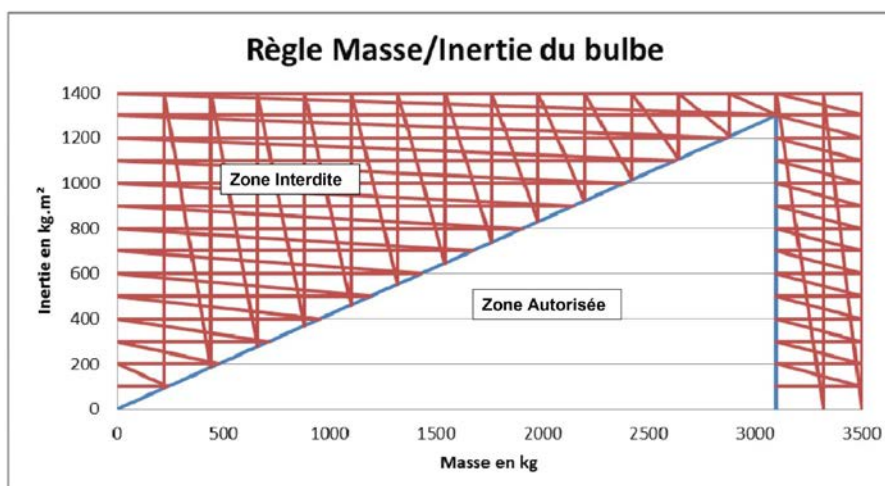

Appendix B-2: Standard canting system description

The standard canting system is supplied by Hydroem.

AB-2.1 PLANS AND ASSOCIATED DOCUMENTS

The following plans and documents are associated with appendix B.

Only the most recent versions and revisions should be consulted:

- 3D Peripherique Electronique – STEP:
 - ARMOIRE CAPAS V2 AVP0.STEP
 - GESTION QUILLE L2 AVP0.STEP
- 3D Peripherique Hydrauliques – IGS:
 - 5 Vase d'expansion.IGS
 - Groupe électro-hydraulique lynch.IGS
 - Manifold.IGS
 - Pompe manuelle.IGS
- 3D Systeme Principal – STEP:
 - 0669 - IMOCA Quille Standard - Assemblage General 0° - date.STEP
 - 0669 - IMOCA Quille Standard - Assemblage General 38° Babord - date.STEP
 - 0669 - IMOCA Quille Standard - Assemblage General 38° Tribord - date.STEP
 - Bras de securite.IGS
 - Verin hydraulique.IGS
- NOMENCLATURES:
 - Bras de securite Nomenclature 3D
 - Groupe electro-hydraulique lynch
 - Manifold Nomenclature 3D
 - Vase d'expansion
 - Verin hydraulique Nomenclature 3D
- Note 1: Cahier des Charges d'implantation et utilisation du système standardisé de basculement V1.2

These plans and documents are available from the *IMOCA* secretariat [contact@imoca.org].

AB-2.2 TECHNICAL DESCRIPTION

[a] Keel head pin

The pin shall have a diameter of 70mm and be made of Inconel 718 (Nickel based Stainless Steel Alloy)

[b] Ram with ball joint trunnion

- i. Hydraulic ram of 17-4PH Stainless Steel, bore diameter \varnothing 140mm, tip and tail in Titanium.
- ii. Rod 17-4PH \varnothing 65 with carbide deposit, 550 mm travel corresponding to 38°.
- iii. Trunnion with cylindrical \varnothing 75 mm bushes.
- iv. Rod end 17/4PH, eye \varnothing 160 with CuBe² beryllium swivel bushing for a \varnothing 70 mm pin.
- v. Position sensor integrated into the rod.
- vi. 2 cupro-aluminium swivel bushings \varnothing 98* \varnothing 75*55 mm.
- vii. 2 aluminium 6083 swivel trunnions of \varnothing 230 mm for a 45 mm thick bulkhead.

[c] Mechanical lock

- i. Titanium female open clevis pin head suitable for the \varnothing 70 mm diameter keel head pin.
- ii. Rod \varnothing 65 mm 17-4PH.
- iii. Kneecapped swivel, \varnothing 75 mm clevis and \varnothing 34 mm rod.
- iv. Aluminium 7075 trunnion with \varnothing 75 mm cylindrical bushes.
- v. Two cupro-aluminium swivel bearings \varnothing 98 * \varnothing 75 * 55 mm.
- vi. Two aluminium 6083 \varnothing 230 mm trunnion bearings suitable for a 45 mm thick bulkhead.
- vii. Titanium \varnothing 60mm split pin.
- viii. Ertalyte ring for baffles attachment.
- ix. Two cupro-aluminium bushings with \varnothing 76mm female clevis pins.

[d] Drilled hydraulic manifold block

- i. 24 Volt Electric release with integrated auxiliary manual system.
- ii. Electrically operated valves with progressive release.
- iii. Overload release valves.
- iv. Anti-cavitation valve.
- v. Flow regulator for release function.

[e] Hydraulic Control System

- i. LYNCH electric motor 24 volts 4500 Watts.
- ii. Half-cant time between 32 and 40 seconds.
- iii. 350 bar rated components.

- iv. 24 V system with manual auxiliary controls.
- v. Moulded watertight cables with control LED indicator lights.
- vi. Damping accumulator.
- vii. Kit of 6 flexible links with Minimesse® junctions and visual manometers.
- viii. 8 litres principal hydraulic oil tank.
- ix. 12 litres air expansion tank with manometer.
- x. Outlet control system capable of functioning at 360°.
- xi. High pressure filter at control system outlet. White epoxy painted control system.
- xii. Separate manual auxiliary pump.

[f] JPS Concept operating controls

- i. Three keel cant control boxes [one internal and two external (Port and Starboard)].
 - ii. A relay box with position indicator.
- Principal functions:

- Keel to Port
- Keel to Starboard
- Release/By-Pass
- Stop
- Keel to the centre plane
- Tacking and Gybing command

[g] Power Pack: 2 Capas + 1 Charger + 1 Container

[h] Summary of the weight estimate of components

- Ram and connecting rod 84 kg
- Set of bearings Ø 250 mm (2x4) 8 kg
- Mechanical locking system 34 kg
- Set of bearings Ø 250 mm (2x4) 8 kg
- 5kg Threaded block
- Valves and connections 1.2 kg
- 4500 watts hydraulic control and manual pump 23 kg
- Expansion tank 2.5 kg
- Control and relay boxes 1.6 kg
- Power pack (Capa) 16 kg

AB-2.3 FIRST USE, OPERATIONS AND MAINTENANCE

• First Use

The first time the *standard canting system* is used it shall be in the presence of the approved supplier. First use shall include sea trials. A certificate of correct installation and use shall be delivered to the client by the approved supplier following successful sea trials.

• Manufacturer's recommendations

All available manufacturer's recommendations are laid out in the operating manual (Note 1) and shall be adhered to in a seamanlike manner for safe use.

The keel system must be correctly protected against electrolysis.

• Inspections and maintenance

The *standard canting system* shall be regularly inspected and maintained.

Maintenance must be carried out by the official supplier or under their control.

Under no circumstances shall the system be dismantled without the express approval of the official supplier.

Inspection and/or maintenance records may be required to renew the MC or [CMC](#).

Appendix C: Standard mast

The *standard mast* is supplied by LORIMA

The design and structural calculations are carried out by GSea Design

AC.1 PLANS AND DOCUMENTS ASSOCIATED WITH APPENDIX C:

[a] The following plans are associated with appendix C. Only the plans with the most recent revisions and/or the most recent date stamp should be consulted.

Mast:

- i. 1050z-01-200 Plan general mat aile - diffusion 2019 revA (Wing mast general arrangement).
- ii. 14000- Renfort ancrage tweaker (Tweaker anchorage reinforcement).
- iii. 14000- Vue de detail extremite Outtrigger (Detailed view of outtrigger outer extremity).
- iv. C12001 Lock car-Model (Halyard slider lock).
- v. 1050z-01-300 Plan de moule - diffusion 2019 revA (Mould drawing).
- vi. 1050z-01-400 Plan de drapage - diffusion 2019 revA (Layout drawing).
- vii. 1050z-03-200 Plan outtrigger - diffusion 2019 revA (Outtrigger drawing).
- viii. HGV-H27Renfort rail_2020_07_23.zip [6 files] (Track reinforcement)
- ix. Updated plans of the mast step with a choice of 2 models
- x. Updated plans of the plates for full mainsail, reef 1-2-3, head car + reef 4 screw.
- xi. Plans of the 'fittings' associated with running backstays, forestays 2, 3 and spare forestay 3.
- xii. [Add new drawings that are available]

[b] Note 2: Mast stepping specification and use of the standard wing mast and PROCEDURE V2 FOR INSTALLATION QF HGV 2020 PLATES.

Note 2 is supplied by the builder when the mast is delivered

To get the best and safety results from the *standard mast* the skipper should use best practice and good seamanship with the guidelines described in Note 2.

These plans and the Note 2 are available from the *IMOCA* secretariat (contact@imoca.org):

The schematics in this document are for illustrative purposes only.

AC.2 MAST STEPPING

The following rules shall apply with regard to the stepping of the mast.

AC.2.1 FORCES AND LOADS

NOTE 2 describes the theoretical static loads and fittings.

The mast installation on the boat shall require compliance with these load cases.

The **hull** structure and all associated equipment shall be built with these loads in mind and with sufficient safety factors to be able to safely compete in OSR Category 0 races.

AC.2.2 POSITION OF CHAINPLATES AND MAST STEP

[a] The 0 reference of the mast [as defined in AC.4[a]] shall be positioned between X= 7700 mm and X= 8700 mm [X=0: it is the aft most point on the **hull**].

[b] The chainplates for the D0s (Tie rods) shall be positioned on the boat such that the angle between the D0 and the Outtrigger is greater than 23.3° in the plane between their two axes.

[c] The minimum and/or maximum of the forestays and running backstays shall comply with the installation of the mast on the deck and are defined in AC.1 [a] i.

They are measured for a 4.0-degree rake.

They are referred to in the table below:

Forestay Number	Forestay Name	Minimum Angle*	Maximum Angle*	Sail set on the Forestay
Forestay 0	J0	22°		J0 or spinnaker
Forestay 1	J1	18.5°		J0 or J1
Fractional Forestay	FRAC			FR0
Forestay 2	J2	17.7°	20°	J2
Forestay 3	J3	17°	21°	J3 or Storm Jib
Running Backstays		14°	18°	* upper position

AC2.3 RAKE AND ROTATION

(a) See F.2 (b).

(b) The mast rotation angle shall not exceed +/- 40° with respect to the centre plane of the boat.

AC.3 RIGGING

(a) Lateral standing rigging

The two cap-shrouds (G1) and the two lower-shrouds (G2) are supplied with the *standard mast*

The SK loops used to attach G1 and G2 to the mast are not supplied with the *standard mast*.

Chafe protection may be installed on the G1 and G2 such that they do not alter their mechanical properties.

Fairings and other systems intended to improve the aerodynamics and/or affect sail trim are expressly forbidden.

(b) Tie-rods (D0)

The two tie-rods are supplied with the *standard mast*.

Their lengths are unrestricted and shall be determined by the client of the standard mast

Chafe and/or impact protection may be installed on the tie rods such that they do not alter their mechanical properties.

Fairings and other systems intended to improve the aerodynamics and/or the hydrodynamics and/or to affect sail trim shall be expressly forbidden.

(c) Forestays and running backstays

The rig of the *standard mast* shall comply with the table below:

	Cable name and sail name	W1 (T)	EA mini (MN)	EA Max (MN)	F Rupture (T)	Maximum pre-tension	Material
Cap shroud	G1	5.5	23.77		28	2	Carbone EC6
Lower shroud	G2	4	12.8		15	1	Carbone EC6
Tie rod	Tie-rod	18	36.74		44	7.5	Carbone EC6
Forestay 0	J0	6.5	11	25	15		PB0 or SK
Forestay 1	J1	7.5	22	28	25		PB0 or SK
Forestay 1 (without sail)	J1 replacement	7	15				PB0 or SK
Fractional forestay	FRAC	5	10	20	15		PB0 or SK
Forestay 2	J2	8	22	28	25		PB0
Forestay 3	J3	5.5	12	18	15		PB0 or SK
Forestay 3 (without sail)	J3 replacement	5	12		15		PB0 or SK
Running backstay	Running backstay	6.5	14	20	20		PB0 or SK
Deflector	Deflector	6	14	20	20	0.2/0.3	SK

The running backstays, forestay 2, forestay 3, forestay 3 (without sail), the running backstays and the deflectors shall be as supplied with the *standard mast*.

Their lengths are unrestricted and their lengths shall be specified by the client of the *standard mast*.

The ropes and loops used to attach these riggings to the mast are not supplied with the *standard mast*.

Protection to combat friction or impact are expressly permitted provided that this does not alter the rigging's mechanical properties.

Fairings or other systems intended to improve the aerodynamics, hydrodynamics or affect sail trim shall be expressly forbidden.

An attachment point added to a sail that is not at the end of the cable may be installed.

AC.4 MAST DESCRIPTION

[a] Tube

- Reference axes: X → horizontal; Y → transversal; Z → vertical
- 0 reference [0 mast = 0 layout]: It is the intersection of the lowest point of the aft face of the tube and the base of the ball of the mast step.

[b] Tube geometry

- Maximum chord 540 mm
- Maximum thickness 285 mm
- Aft face width 45 mm
- Tube length 27300 mm from the masthead to the bottom of the mast step

[c] Tube weight and centre of gravity position:

- Vertical position of the rig centre of gravity: 11.06 m +/-1%
- Rig weight: 370 kg (including corrector weights)
- Rig reference static moment 4×10^6 kg.mm

The CM shall add corrector weights if necessary, to bring the rig weight up to 370Kg. They shall be sealed in place in the defined position.

[d] Mast track and mainsail halyard hook

- Mainsail mast track: HARKEN HGV-H27
- Mainsail head car: Lock with internal remote-control HARKEN HGV-H27
- Fixings: A4-80 [threaded only in the carbon]
- Reinforced area over 300mm at each reef level [See AC.1 [a][viii] & [b]]

[e] Mainsail head altitude

- Full mainsail Z = 27300 mm
- First reef Z = 23500 mm
- Second reef Z = 19400 mm
- Third reef Z = 14700 mm
- Fourth reef Z = 9207 mm

[f] Mast step

- The mast is stepped on a ball
- The mast step is supplied with the *standard mast*
- The halyards may pass through the ball

[g] Rotation arm

- A single attachment point at Z = 370 mm on the forward face of the mast tube.
- The section is stiffened by an omega to prevent warping.

[h] Gooseneck

- The gooseneck is a carbon bracket with bushing and a pin.
- Altitude Z = 700 mm
- Under the gooseneck, in the reinforcement, 2 double friction sheaves may be used to deflect the lock control and the sheet blocks.
- The loads and conditions of use are described in Note 2.

[i] Cunningham

- At the level of the gooseneck, in the reinforcement on the starboard side, a toggle may be used to terminate the Cunningham.

[j] Boom vang

- No boom vang or system designed to adjust the leech tension of the mainsail shall be attached to the mast and/or the mast step.

[k] Radar

- 1 reinforcement and cable hole and/or support bracket attachment is situated on the forward face of the mast.
- The centre of the radar cable hole shall be positioned at an altitude Z between 3462 and 3676 mm
- The radar bracket shall be bonded to the mast and is not supplied with the standard mast.
- A mooring light and foredeck lights may be installed in proximity to the Radar bracket.

[l] Lazyjacks

- The lazyjacks shall be attached to the lower shroud attachment points or their loops.

[m] Shroud Attachment points

- Upper shrouds: Altitude Z= 25600 mm
- Lower shrouds: Altitude Z= 13500 mm

[n] Forestay attachment points

- The attachment points are toggle designed to support a halyard lock with a Dyneema loop. The halyard exits are situated below the attachment points.
- J0: Altitude Z= 27250 mm
[The J0 attachment point is specified to be used by the J1 if required]
- J1: Altitude Z= 26900 mm
- FRAC: Altitude Z= 22500 mm
- J2 (Fixed forestay): Altitude Z= 22100 mm
- J3: Altitude Z= 15500 mm

[o] Running backstays

- Masthead running backstay: Altitude Z= 26800 mm
- Lower deflector: Altitude Z= 22200 mm
- Deflector is fitted with a 'Hook' that has two positions [ON/OFF]
- Deflector shall be pre-tensioned to 0.2 to 0.3 tonnes in the OFF position.

[p] Masthead

- The masthead is a laminated U-shaped carbon sheave box.
- Mainsail halyard: A single fixed point can be used for the main halyard termination.
- The electronic masthead units, antennas and navigation lights are not supplied with the standard mast. Their installation and mounts are unlimited by the CR.

[q] Protection

- A protective patch may be placed on the mast. It shall be required to demonstrate that these patches are non-structural and are solely for the purpose of protecting the mast.
- Under the radar, 'soft padeyes' may be attached to the mast to serve as deflector terminals or to attach unused halyards to.
- The mast step may have a mast rotation angle sensor device attached to it.
- The mast shall be painted and may be decorated with advertising vinyls.
- [And conforming to appendix G for the CMC.](#)

[r] Outriggers

- Outrigger lengths: 6250 mm.
- The outriggers shall be stepped in the mast step supplied with the standard mast.
- The outriggers may be used for headsail trim, under the following conditions only

Outrigger use conditions:

The outrigger is structured, along its length, to accept a maximum working load perpendicular to the axis of 1T. Any load applied to the outrigger shall be made via a textile strop with a minimum width of 50mm. This strop shall apply the previously specified load solely in the 350 mm zone as described in the drawing entitled "14000-Renfort ancrage tweaker".

This strop shall be retained in place along the longitudinal axis of the outrigger so as to avoid crushing the tube at the point of attachment. The strop diameter shall be sufficient to avoid causing the tube to crush along its periphery when under load, regardless of orientation.

The stop shall not transfer rotational loads onto the outrigger such that the cap shroud terminal fitting acts as a stop. The termination of the retainer shall not be attached to the standing rigging.

[S] Choosing to use optical fibre is expressly permitted. This standard solution shall not be modified.

AC.5 DELIVERY

[a] *IMOCA* shall issue a serial number to each standard mast that shall be clearly displayed on that standard mast.

[b] The entire standard package shall be delivered with:

[i] A certificate of conformity;

[ii] Note 2;

[iii] The results of the rig configuration study as defined by *IMOCA* associated to the CMC.

[c] A delivery receipt from the supplier and approved by the client.

Appendix D: Exemptions from OSR Cat 0

[Agreed by the FFVoile until 31/12/2021]

Exemption No.1 OSR 3.03 [Hull Construction Standards] is replaced by CR: D.1 [c] and [d].

Exemption No.2 OSR 3.13.1 [Watertight Bulkheads] is replaced by CR: D.8.1.

Exemption No.3 OSR 3.13.5: [Access Hatch Closure] is replaced by CR: D.8.2.

Exemption No.4 OSR 3.14.6 [Lifeline Specifications] is replaced by FFVoile Prescription No. 4 and CR: C.9.2 [c].

Exemption No. 5 la RSO 3.19.1 [Bunks] is replaced by CR: C.10.1.

Exemption No.6 OSR 3.23 [Bilge Pumps and Buckets] is replaced by CR: C.3.2.

Exemption No.7 OSR 3.18.1 [Toilet] is replaced by: Solely for singlehanded or double-handed races, OSR 3.18.1 is replaced by FFVoile Prescription No.6: "There must be a bucket fitted and allocated for this sole use, secured in a dedicated site."

For crewed races, OSR 3.18.1 is replaced by CR: C 10.4.

Exemption No.8 OSR 3.28.1 b) [Propulsion Engines] is replaced by CR: C.6.1 [b].

Exemption No.9 Solely for singlehanded or double-handed races: OSR 3.29 [AIS] is replaced by CR: C.7 [b] and [d].

Exemption No.10 OSR 3.29.3 [Watertight Satellite Telephones] is replaced by CR: C3.20 [b][ii] and C7.2.

Exemption No.11 OSR 3.29.11 [Radar] is replaced by CR: C.3.14.

Exemption No.12 OSR 4.02.1 [Search and Rescue Visibility] is replaced by CR: C.8.

Exemption No.13 OSR 4.05.2 [Fire Extinguishers] is replaced by la prescription FFVoile No.10 and CR: C.3.12.

Exemption No.14 OSR 4.07.1d) [Searchlights] is replaced by CR: C.3.22.

Exemption No.15 OSR 4.10.1 [Passive Radar Reflector] is removed.

Exemption No.16 OSR 4.13.2 [Depth Sounders] is replaced by CR: C.7.2 [h].

Exemption No.17 OSR 4.20.1.c), 4.20.2.a) and 4.20.3.c) [Life Rafts] are replaced by CR: C.3.4.

Exemption No.18 OSR 4.20.1 [Life Rafts] is completed by: "4-person life rafts stored in a SOLAS-type bag are acceptable".

Exemption No.19 OSR 4.26.2[c) [Trysail] is replaced by FFVoile Prescription No.14.

Exemption No.20 OSR 4.30 [Emergency Pumps] is replaced by CR C.3.2.

Exemption No.21 OSR 5.03 [Personal Location Lights] is replaced by CR C.3.8 [b] and [d].

Appendix E: Branding plan

The branding plan is available from the *IMOCA* secretariat [contact@imoca.org].

Appendix F: CRC / Measurers

Composition of the CRC

- Daniel Andrieu: Naval Architect
- Simon Forbes: World Sailing
- Philippe Pallu de la Barrière : C.R.A.I.N.

List of Official *IMOCA* Measurers

- IMOCA Chief Measurer: René BOULAIRE: chief.measurer@imoca.org
- Official IMOCA Measurers:
 - Europe: Manu GUEDON: manuguedon@free.fr
 - New Zealand: Jim MC ELREA: jmcclrea@xtra.co.nz

Appendix G: Material limitations, construction methods, finishing products to obtain a CMC.

AG.0 DEFINITION

Bio-composite: material which uses reinforcements and resins of animal or vegetable origin. It consists of a combination of thermoplastic or thermosetting resins and reinforcements in the form of microspheres, fibres, cloth or non-cloth.

AG.1 MATERIALS

The **boat**, without **sail(s)**, in the lightweight configuration [without associated electrical, electronic equipment] shall be built using the following materials which shall be commercially produced, unless subject to a specific authorisation or ban described in the CR, in appendix G or from the CM:

- Aluminium.
- Steel, stainless steel.
- Titanium.
- Bronze, lead.
- Epoxy, polyester and vinylester resin,
- Glass fibre, aramid fibre and carbon fibre with a tensile modulus less than 280 Gpa.
- Nomex® [Aramid Honeycomb Paper], PVC or SAN foam.
- Wood.
- Moulded plastic and thermoplastic.
- Paint and other chemical products in compliance with appendix AG.3.
- The rigging [running and standing] shall be of Carbon, Aramid, Vectran, SK, Polyethylene, Polyester and/or PBO.

All composite components of the boat [including the **hull**, [not including the associated fittings] the foils and rudders, the boom and spars] except the **sails**, shall conform to the following specifications:

- The fibres listed below are permitted:
 - Hexcel®: IM 7 [6k]; IM2A; IM2C; AS7.
 - Mitsubishi Chemical Carbon Fiber and Composites®: MR40; MR60H.
 - Tenax®: IMS 60; IMS 65.
 - Toray®: T800H; M30S; T700S.
 - Tornel®: T650/42.
 - T800SC.

All other fibres shall have a nominal modulus less than 280Gpa.

- HM fibres are expressly prohibited except for the boom, spars and foils which may have M40J, M46J and HS40 fibres.
- Nomex® [Aramid Honeycomb Paper] or foam [PVC and SAN] shall be the only core materials used.
Para-aramid [N636 or equivalent] or metallic cores shall be expressly forbidden.
The core materials shall be commercially produced.
- The nominal weight of each glue film or weight of any combination of adhesive layers used to glue Nomex® [Aramid Honeycomb Paper] or foam cores shall be at least 300g/m².
- Nanotechnologies, nano-sciences and other associated sciences and technologies shall be expressly forbidden in any resin system for any part of the **boat**, with the exception of the sails.
- The nominal weight of each ply shall be at least 150g/m².

AG.2 CONSTRUCTION METHOD

[a] The **hull**, excluding associated fitout, the *foils* and *rudders*, shall not be heated to temperatures above 135°C during the manufacturing process and possible post curing stages.

[b] The hull shell and deck, excluding internal structure, associated fitout and all corrector weights, shall not be built using an autoclave. The maximum pressure applied for vacuum assisted construction shall not exceed 1.1 Bars.

[c] From 8 November 2020, *foil* stocks shall be built solely of carbon and resin monolithic which complies with Appendix G.

AG.3 FINISHING AND PAINTING for the hull shell and the *hull appendages*.

[a] All products used for finishing and painting shall be *commercially produced*.

[b] Plastic films and vinyls may be used for the sole purpose of decorating and branding the boat.

[c] The *working deck* and all surfaces where any member of the crew needs to move to when under way shall be finished with a non-slip surface.

Appendix H: Lightweight configuration

Putting the **boat** into *lightweight configuration* shall be the responsibility of the *skipper* or their designated representative who must sign the *checklist*.

Each piece of the **boat's** equipment shall be stowed in the position it would be during a *race*, in accordance with the CM.

All equipment designed to charge the batteries by generating *renewable energy* (hydrogenerators, solar panels, wind turbines...) without any kind of fuel, shall not have their weight included in the displacement of the boat in *lightweight configuration*.

For each step described below a set of photographs shall be provided.

These photographs may be used as proof/verification within the boat's measurement files.

BOAT EXTERIOR:

- The spars, all standing rigging, all running rigging and associated equipment and deck fittings
- Running backstays in their normal position (slack taken up, including that of the deflectors).
- All halyards brought to the foot of the mast (with their locks if they are so equipped).
- Furling drums in position with their associated running rigging.
- All mobile and fixed deck gear.
- Lifelines, pushpits, pulpits, stanchions, navigation lights.
- Mobile cockpit protection equipment if any, in the closed position (solid or fabric canopy)
- Cabling and antennas associated with the VHF and AIS systems.
- Operational Radar installed.
- Electronic equipment powered electrically or otherwise installed (various antennas, etc...)
- All electronic equipment connectors installed.
- Other equipment connectors installed (pilot, electronics, IT, etc...).
- Keel at zero degrees cant (0°).
- *Hull appendages* installed in the 'fully lowered' position except when their respective positions are defined in a rule or by the CM.
- *Rudders* in the lowered position.

BOAT INTERIOR:

- *Standard canting system* or any keel canting system.
- Fresh water tanks checked empty.
- Water ballast tanks and associated plumbing checked empty.
- All watertight bulkhead hatches and locking mechanisms in place.
- Operating "main" propulsion unit, and if a diesel engine, with engine sump with correct level of oil, and with all associated equipment (shaft, propeller, etc...).

- Engine starter (batteries, super capacitor, etc...) with the full recharging system.
 - Fixed fuel tanks empty except for a minimum (minimum 5 litres) allowing powered manœuvres for the purposes of measurement.
 - All other tanks empty with the exception of the hydraulic systems tanks used in normal sailing trim.
 - All house batteries (not including the engine starting battery) with their associated charging systems installed.
 - The permanently installed draining system as described in Article C.3.2(b) and associated equipment
 - Interior fitout.
 - Navigation seat if solid.
 - The number of *bunks* required to comply with C.10(a) and (b).
 - Kitchen stove installed and operational (including combustible tank).
- The equipment described in Articles C.7.1(a), C.7.2(a) & (b) & (e) & (f) & (g) & (h) & (i) and C.3.14 shall have to be operational.

Shall be removed from the boat:

- **Sails.**
- Mainsail lazyjacks.
- Flying deck-gear and running rigging not listed above.
- Anchors with warps and chain.
- Safety equipment.
- Outriggers, if any (spreaders, jockey poles, etc., not included in the *standard mast*)
- All moveable equipment not attached or linked to the boat.
- All consumable, freshwater cans, the emergency fuel tank and navigation equipment.
- Clothing, victuals, personal effects.
- In general, any other piece of equipment as required by the CM.
- **Communication equipment supplied by TOR and scientific equipment.**

Appendix I: Interpretations

These documents are available from the *IMOCA* class secretariat [contact@imoca.org].

Appendix J: Reserved

Appendix K: *IMOCA* Measurement Certificate and associated documents

Appendix K-1: *IMOCA* Measurement Certificate

This document is issued by *IMOCA* and prepared by the CM [chief.measurer@imoca.org].

Appendix K-2: New build declaration form

This document is available from the *IMOCA* class secretariat [contact@imoca.org].

Appendix K-3: Documents to be supplied to the CM to obtain a MC/CMC

The document list is described in the *measurement protocol* and prepared by the CM [chief.measurer@imoca.org]

Appendix K-4: MC/CMC renewal request form

This document is available from the *IMOCA* class secretariat [contact@imoca.org].

Appendix L: Contacts

IMOCA

Headquarters

IMOCA – C/o FFV - 17, rue Henri Bocquillon – 75015 PARIS – FRANCE

Office

IMOCA – 7, rue Honoré d'Estienne d'Orves – 56100 LORIENT - FRANCE
+33 (0) 631 435 627

President - Antoine MERMOD: antoine.mermod@imoca.org

Head of operations - Louis VIAT: louis.viat@imoca.org

Administration, Measurement Coordination & Team liaison - Marine LE TEXIER KERDUEL : contact@imoca.org

Chief Measurer - René BOULAIRE: chief.measurer@imoca.org

IMOCA website: www.imoca.org

World Sailing

General Secretariat: secretariat@sailing.org

Simon FORBES – Technical Manager: simon.forbes@sailing.org

Suppliers chosen by *IMOCA*

AMPM : 16 Rue de la Camamine, 85150 La Mothe-Achard - FRANCE
Contact : Fabien Dillet : +33 (0)2 51 94 76 38 et +33 (0)6 08 36 45 64

Gsea Design : 19, rue Jules Guesde, 56100 Lorient - FRANCE
Contact : Benjamin Madec +33 (0)2 97 78 11 91

Hydroem : 4 Rue Eugène Freyssinet, 17140 Lagord - FRANCE
Contacts : Francis Merieau : +33 (0)6 11 54 19 01 & Michel Farre : +33 (0)6 03 47 93 46

Iridium : Iridium Satellite LLC 1750 Tysons Boulevard, Suite 1400 McLean, VA 22102 - USA
Contact : Dan Rooney dan.rooney@iridium.com

Iroise Rigging : 35 Rue Ingénieur Verrière 56100 - Lorient
Contact : Eric Cochet : +33 (0)6 80 74 63 02

Lorima: 7 Rue du Commandant l'Herminier, Base des sous-marins, 56100 Lorient - FRANCE
Contact : Nicolas Rabillé : +33(0) 6 80 23 08 12

Thalès : Thales Defense & Security Inc. 22605 Gateway Center Drive Clarksburg, MD 20871 - USA
Contact: Luciana Valdiviezo luciana.valdiviezo@us.thalesgroup.com

Appendix M: Reserved

Appendix N: Sail Identifications

This document is available from the *IMOCA* secretariat [contact@imoca.org].

Appendix O: Reserved

Appendix P: Standard Communication System

The *standard communication system* is supplied by the companies Thales and Iridium.

A VesseLINK 700 terminal with activated SIM card shall be on board.

There must be no visible branding on the devices or antennae from a brand that is in competition with the suppliers chosen by *IMOCA*.

AP.1 PLANS AND DOCUMENTS ASSOCIATED WITH APPENDIX P:

[a] The following plans are associated with appendix P.

[b] Note 4.

AP.2 INTEGRATION ON THE BOAT

AP.3 DESCRIPTION