



**INTERNATIONAL MNOHULL OPEN CLASS
ASSOCIATION**

WORLD SAILING INTERNATIONAL CLASS

Class Rule 2028

(English version)

**Text approved at the IMOCA General Assembly on 9 April 2026
and applicable from the first race of the 2026 IMOCA Globe
Series Championship**

**Version : 3
Amendment included : 0**

Changes to Class Rule 2028 V2.0 are indicated by a vertical line to the left of the text.

Date : 10/04/2026

CONTENTS

CONTENTS	2
INTRODUCTION	6
CHAPTER I ADMINISTRATION	7
SECTION A GENERAL REMARKS.....	7
A.1 LANGUAGE.....	7
A.2 ABBREVIATIONS & DEFINITIONS.....	7
A.3 AUTHORITY.....	11
A.4 MANAGEMENT OF THE CLASS.....	11
A.5 CLASS MEMBERSHIP	11
A.6 CHANGES TO THE CLASS RULES.....	11
A.7 INTERPRETATIONS OF THE CLASS RULES.....	12
A.8 BOAT MEASUREMENT AND INSPECTION.....	12
A.9 <i>IMOCA</i> MEASUREMENT CERTIFICATE.....	14
A.10 DOCUMENT STORAGE.....	15
A.11 EXCEPTIONAL CASES.....	15
SECTION B ELIGIBILITY	16
B.1 CLASS RULES AND CERTIFICATION	16
B.2 HULL AND SAIL NUMBERS	16
CHAPTER II CONDITIONS AND RESTRICTIONS.....	16
SECTION C CONDITIONS FOR RACING.....	16
C.1 MOVABLE BALLAST	16
C.2 OUTSIDE HELP, SERVO POWER AND MANOEUVRING	17
C.3 SAFETY EQUIPMENT.....	17
C.4 MEDICAL AND SURVIVAL TRAINING.....	23
C.5 ADVERTISING	23
C.6 ENERGY / ENGINE.....	23
C.7 NAVIGATION.....	26
C.8 IDENTIFICATION	27
C.9 BOAT : FITTINGS AND EQUIPMENT.....	27
C.10 BOAT : LIFE ON BOARD.....	30
C.11 HYDRAULIC SYSTEMS	31
C.12 IDENTIFICATION ON SAILS	31
SECTION D HULL.....	31
D.1 FUNDAMENTAL RULES	31
D.2 DIMENSIONS.....	31
D.3 HULL MATERIAL LIMITATIONS.....	32
D.4 BUOYANCY.....	32

D.5	STABILITY AND RIGHTING MOMENT LIMITS.....	32
D.6	WATER BALLAST	33
D.7	COCKPIT.....	33
D.8	WATERTIGHT COMPARTMENTS.....	33
D.9	HATCHES AND EMERGENCY EXITS.....	34
SECTION E	HULL APPENDAGES.....	35
E.1	GENERAL REMARKS	35
E.2	KEEL	36
E.3	BULB.....	37
E.4	FOIL	37
E.5	RUDDER.....	38
SECTION F	RIG.....	39
F.1	STANDARDISED MAST	39
F.2	AIR DRAUGHT AND MAST	39
F.3	STANDING RIGGING.....	39
F.4	OUTRIGGERS.....	39
F.5	STANDARDISED BOOM	40
SECTION G	SAILS.....	40
G.1	GENERAL REMARKS	40
G.2	LIMITATIONS.....	40
G.3	HEADSAILS	40
G.4	IDENTIFICATION	41
G.5	SAIL MATERIAL	41
SECTION H	ELECTRONIC EQUIPMENT	41
CHAPTER III	APPENDICES TO THE CLASS RULES.....	41
APPENDIX A	GRANDFATHER RULES.....	41
AA.1	GENERAL REMARKS	41
AA.2	HULL	41
AA.3	STRUCTURE AND NDT OF THE BOAT	42
AA.4	STABILITY.....	42
AA.5	KEEL	42
AA.6	MAST AND RIGGING.....	43
AA.7	BOOM	43
AA.8	PULPITS AND LIFELINES.....	43
AA.9	FOIL	43
AA.10	FOIL MEASURED FOR THE FIRST TIME BEFORE 15TH OCTOBER 2020	43
AA.11	FOIL MEASURED FOR THE FIRST TIME BEFORE 15TH OCTOBER 2021	44
AA.12	ELECTRONIC EQUIPMENT.....	44
AA.13	GRANDFATHER RULES WICH APPLY FOR A BOAT WITH A FIRST MC.....	44

AA.14 ENERGY / ENGINE	44
AA.15 SAILS	44
AA.16 STANDARDISED MAST	44
AA.17 HYDRAULIC SYSTEMS	45
APPENDIX A-1 DESIGN OF A NON-STANDARDISED KEEL FIN	45
APPENDIX B STANDARDISED KEEL FIN AND CANTING SYSTEM	47
APPENDIX B-1 STANDARDISED KEEL FIN	47
APPENDIX B-2 STANDARDISED CANTING SYSTEM DESCRIPTION	49
APPENDIX C STANDARDISED MAST.....	51
AC.1 PLANS AND DOCUMENTS FOR THE 1ST GENERATION MAST	51
AC.2 PLANS AND DOCUMENTS FOR THE 2ND GENERATION MAST	51
AC.3 MAST STEPPING.....	51
AC.4 RIGGING.....	52
AC.5 MAST DESCRIPTION	53
AC.6 DELIVERY.....	56
APPENDIX D OFFSHORE SPECIAL REGULATIONS.....	56
APPENDIX E BRANDING GUIDELINES.....	56
AE.1 MAINSAIL BRANDING	57
AE.2 BRANDING ON THE CLOTHES OF THE SKIPPER, CREW AND TECHNICAL TEAM	58
AE.3 IN-PORT PROMOTIONAL SAIL	59
APPENDIX F CRC / MEASURERS.....	60
APPENDIX G MATERIAL LIMITATIONS, CONSTRUCTION METHODS AND FINISHING PRODUCTS	61
AG.0 DEFINITIONS.....	61
AG.1 MATERIALS	61
AG.2 CONSTRUCTION METHODS	62
AG.3 FINISHING AND PAINTING.....	63
AG.4 ENVIRONNEMENTAL IMPACT REDUCTION OF CONSTRUCTIONS.....	63
APPENDIX H MEASUREMENT TRIM.....	64
APPENDIX I INTERPRETATIONS	66
APPENDIX J ALTERNATIVE MATERIAL.....	66
APPENDIX K MEASUREMENT CERTIFICATE AND DOCUMENTS.....	67
APPENDIX K-1 IMOCA MEASUREMENT CERTIFICATE.....	67
APPENDIX K-2 NEW BUILD DECLARATION FORM	67
APPENDIX K-3 DOCUMENTS TO BE SUPPLIED TO THE CM TO OBTAIN A MC	67
APPENDIX K-4 MC RENEWAL FORM	67
APPENDIX L CONTACTS.....	67
APPENDIX M STANDARDISED BOOM.....	68

AM.1 ASSOCIATED PLANS AND DOCUMENTS	68
AM.2 INSTALLATION ON THE BOAT	68
APPENDIX N SAIL IDENTIFICATIONS & LIMITATIONS	68
AN.1 PRINCIPLES	68
AN.2 HOW IT WORKS	69
AN.3 REDUCED IMPACT SAIL	69
APPENDIX O FOIL LIMITATIONS & IDENTIFICATION	69
AO.1 PRINCIPLES	69
AO.2 HOW IT WORKS	70
APPENDIX P ELECTRONIC EQUIPMENT	70
APPENDIX Q MEDIA REPRESENTATIVE (OBR).....	70

INTRODUCTION

These rules define the prohibitions, restrictions and requirements with which IMOCA competing in ocean racing shall comply.

The IMOCA Class Rule is an open class rule, meaning that anything not specifically prohibited, restricted or imposed is permitted.

These rules are constantly reviewed to evolve in favour of :

- safety at sea ;
- sporting equity ;
- technical and sustainable innovation for performance ;
- cost control for boats and campaigns ;
- “sustainable development” of boats and our sporting practices.

The rules relating to equipment manufactured by IMOCA's chosen suppliers apply solely to IMOCA fitted with this equipment.

The IMOCA class has been a World Sailing approved « International Class » since 2001.

IMOCA'S COMMITMENTS

- Commit to promote the preservation of the environment and the protection of marine biodiversity.
- To put in place all the necessary resources to meet the annual goals set by the IMOCA Team Charter.
- To respect the IMOCA Code of Conduct.
- To commit to optimising the use of renewable energy with the aim of being self-sufficient in energy by 2028.
- To adhere to World Sailing's Environmental Code.
- To measure and understand one's carbon footprint in order to meet the goals set by the Paris Agreement in 2030.
- Put in place a life cycle assessment using the « Marine Shift 360 » tool to evaluate the carbon footprint for the build of all new boats.
- To commit to adopting an approach to prevent collisions at sea.

ENVIRONMENTAL CODE FOR OFFSHORE RACES

World Sailing and IMOCA have committed to promoting environmental protection.

As a general rule and when offshore racing, teams shall:

- Use grey and black holding tanks where fitted, and empty them at appropriate pump-out stations on land, or when more than 6 nautical miles offshore.
- Use absorbent cloths to collect any oil in the bilges, and dispose of them in dedicated oil disposal containers on land.
- Use environmentally friendly cleaning products suitable for the marine environment.
- Keep rubbish aboard which can be recycled once ashore, except during long passages when biodegradable rubbish may be disposed of overboard.
- Not use 2-stroke engines.
- Use solar, wind or any other power generated by the speed of the boat wherever possible.
- Use toilets ashore when the boat is in port.
- Follow the recommendations of the IMO (International Maritime Organisation) with regard to biological antifouling products.

CHAPTER I ADMINISTRATION

SECTION A GENERAL REMARKS

A.1 LANGUAGE

A.1(a) French and English are the two official IMOCA languages.

In the event of a discrepancy with regard to translation, the French text shall prevail.

A.1(b) The words "shall" and "must" indicate that something is mandatory.

A.1(c) With the exception of the titles of the appendices, paragraphs and Notes, the terms printed in :

- **"bold"** refer to an ERS definition ;
- **"italics"** refer to a RRS definition ;
- **"italics and underlined"** refer to a definition specified in the CR.

A.2 ABBREVIATIONS & DEFINITIONS

A.2.1 ABBREVIATIONS

CM	<u>IMOCA</u> Chief Measurer
CR	<u>IMOCA</u> Class Rule(s)
CRC	<u>IMOCA</u> Class Rules Committee
ERS	Equipment Rules of Sailing
FFV	French Sailing Federation
GMDSS	Global Maritime Distress and Safety System
IRPCAS	International Regulations for the Prevention of Collision at Sea
ISO	International Organisation for Standardisation
MC	<u>IMOCA</u> Measurement Certificate
NDT	Non-destructive Material Test
OSR	Offshore Special Regulations
PBO	Zylon® or equivalent fibres
RM	Righting Moment
RRS	Racing Rules of Sailing
SK	Dyneema®, Spectra® (UHMWP fibres)
WS	World Sailing

A.2.2 DEFINITIONS

A definition in the singular includes the plural and a masculine definition includes the feminine.

Active sail : A sail, associated with a button, for which the sum of the coefficients associated with the races in which it was declared is strictly less than 10.

Air draught : The vertical distance between the highest point of the mast or sails and the boat reference XY plane.

Battery : a set of accumulators wired in series (or in series/parallel) and constituting a single physical unit.

Battery bank : a set of batteries electrically connected (in parallel/series) to increase capacity and/or voltage.

Boat : The equipment used by the crew to take part in a race.
This includes: **hull**, **hull appendage(s)**, **ballast**, **rig**, **sail(s)**, fittings and all other items of equipment used, but excludes consumables, **personal equipment** and **portable equipment**.

Boat : **hull**, **hull appendages**, ballast and **rig** excluding the structure, **sails**, fittings and any associated mounts, watertight bulkhead hatches and escape and emergency exit hatches, companionway hatch(es), and all other items of equipment used, consumables, **personal equipment** and **portable equipment**.

Boat reference : orthonormal X, Y, Z reference on which the **boat** is positioned at rest, with zero heel and in **measurement trim**. The X axis is the intersection of the **hull centreplane** and the waterplane. The X axis originates from the **hull**'s aftermost point on the **hull centreplane**. The X values increase towards the bow. The XY plane is horizontal and corresponds to the waterplane.

Bunk : A layout designed for sleeping.

Button : A unique distinctive mark – following the description of the **measurement protocol** – affixed to the referenced **sail**.

Checklist : The **measurement trim** inspection and compliance document. This document can be found in the **measurement protocol**.

Cloth : A ply of fibres, unidirectional or otherwise.

Coefficient : Coefficient corresponding to the rank of the relevant race in the “IMOCA Globe Series” Championship as defined in the **measurement protocol**.

Commercially produced: A product or item of equipment available to all competitors, at market price and within a reasonable timeframe.

Modifications made to this product or item of equipment shall be limited to its correct installation, use or set-up and must be able to be validated by the CM.

Crew : A group of more than three people brought aboard *for a race* which may include a **media man (OBR)**.

Degree of freedom : The possibility to effect translational or rotational motion, along or around any axis.

Draught : The vertical distance between the lowest point of the **boat** and the **boat reference** XY plane.

Eco Score tool : The tool developed internally by **IMOCA**, which sets out the leeway available to teams, builders and architects for the construction of a new boat, in order to implement emission reduction measures based on the Global Warming Potential criterion.

Existing sail : A **sail**, associated with a **button**, for which the sum of the **coefficients** associated with the races in which it was declared is greater than or equal to 10 – or – a **sail** identified by the CM and having been used in a race in the “IMOCA Globe Series” Championship before 1st January 2023.

Foil : A **hull appendage** used to produce lift and/or affect leeway, or stability, or elevation, or righting moment.

Helm station : Area within reach of the **boat's** helm(s), including the stick if the helm is equipped with one.

Hull : The hull shell, including the transom, the deck including any superstructure, the internal structure including the cockpit(s), and the fittings associated with these parts.

Hull : The hull shell, including the **transom**, the deck including any superstructure, and the internal structure including the cockpit(s).

Hull appendage : Any item of equipment which is wholly or partially below the **sheerline** or its extension, when fixed or when fully exposed if retractable, attached to the hull shell or to another **hull appendage**, and used to have an effect on stability, leeway, steerage, directional stability, motion damping, trim, displaced volume.

Hull centreplane : The median XZ vertical plane of the **boat reference**.

Hull length : The shortest distance between the two planes perpendicular to the **hull centreplane** and the **boat reference** XY plane, passing through :

- the aftmost point of the **hull** with its **hull appendages** ;
- and the forwardmost point of the **hull**.

Pulpits, pushpits, stanchions, antenna mounts and their antennas, wind generators, solar panels and **hydrogenerators** are not included in the calculation of the **hull length**.

Hydrogenerator : A system for generating electricity using a submerged propeller driven by the movement of the boat.

IMOCA : a term to designate the association that manages WS's International **IMOCA** Class or to designate a sailing **monohull** whose **hull length** is a maximum of 60 feet and which meets the rules and norms described in the CR.

In-port promotional sail : A standardised item of equipment used only in port for communication and promotional purposes.

Keel : The **standardised keel fin** with its bulb that shall be considered as a single **hull appendage**.

LOA : The **hull length** to which the forward and aft spar overhangs are added.

Life cycle assessment : Identification and quantification of the material and energy associated with human activity, from the start of the build of a **boat** until the end of its life.

Measurement protocol : A document that describes all the measurement, calculation and inspection procedures and methods used to measure an **IMOCA**.

Measurement trim : The configuration of the **boat** along with the conditions required are described in CR APPENDIX H.

Media Representative (OBR) : A person on board responsible for communicating about the race as it unfolds. This person must comply with the CR as well as APPENDIX Q, in the same way as every other member of the crew.

Monohull : A **boat** with one **hull**:

- with a single waterplane in **measurement trim** or under sail in normal sailing trim, excluding any waterplanes which may be created by **hull appendages**, the rig, the **hydrogenerators**, or the “main” engine propulsion system.
- of which the hull shell depth beneath the widest point of all transverse sections shall not decrease towards the centreline of the **boat** (see CR D.1(b)).

Mutualisation of tooling : the action of sharing the cost of design, manufacture and the use of tooling for the manufacture of **hull** components whose constructions follow one another over time. The mutualisation refers to and involves the organised and planned cooperation of several teams.

Number of appendages : Defined by the number of intersections between a **hull appendage** and the hull shell.

Reduced impact sail : A **sail** with a RISE analysis rating, as defined in the **measurement protocol**, between A and C included.

Renewable energy : Energy that is generated by the sun and/or the sea and/or the wind.

Rudder : A movable **hull appendage** primarily used to affect **yaw** and which shall not be designed to produce lift.

Sail : An item of equipment, used to propel a specific **boat**. It includes any of the following added parts: sail reinforcements, batten pockets, windows, stiffening.

Scientific equipment : Multidisciplinary equipment or instruments which serve to increase knowledge and/or observation of the marine and aquatic environment and which do not assist with a **boat**'s performance.

Sheerline : The line formed by the intersection of the top of the deck and the outside of the **hull** shell, each extended as necessary.

Skipper : The **IMOCA** member responsible for the **boat when racing**.

Standardised boom : A **spar** attached to the **boat** and on which the mainsail **clew** can be connected. This spar is manufactured by suppliers chosen by **IMOCA** in line with the specifications described in CR APPENDIX M.

Standardised canting system : The complete canting system for the **standardised keel fin** manufactured by suppliers chosen by **IMOCA** in line with the specifications described in CR APPENDIX B.

Standardised keel fin : A **hull appendage** to which a single bulb is attached and is primarily used to affect stability and leeway. This **hull appendage** is manufactured by suppliers chosen by **IMOCA** in line with the specifications described in CR APPENDIX B.

Standardised liferaft : An item of equipment manufactured by suppliers chosen by **IMOCA** in line with the specifications described in the measurement protocol.

Standardised mast : A mast with outriggers and rigging manufactured by suppliers chosen by **IMOCA** in line with the specifications described in CR APPENDIX C. It shall be :

- the 1st generation **standardised mast** built before and until 1st November 2024;
- or the 2nd generation **standardised mast** built from 1st January 2025 onwards.

Sustainable development (within IMOCA) : the ability to promote sustainable and innovative performance whilst maintaining an intrinsic balance between the social, economic and environmental activities in our day-to-day activities.

Through-hull fitting : A system which allows for an opening through the hull shell and meets the requirements of the CR.

Transom : The aftermost structural element which connects the hull to the deck and/or cockpit, and which closes the aftermost watertight compartment.

Transverse : For a watertight bulkhead to be transverse, it must be continuous between the starboard side of the **hull**, the port side of the **hull** and the deck.

Watertightness : protection of an element from external bodies, whether solid or liquid, expressed by means of IPXX Protection Indices, the first number referring to protection from solid bodies and the second from liquid bodies.

Working deck : All areas delimited by pulpits/pushpits, stanchions, lifelines, and guard rails, where a crewmember has to frequently stand or walk, or move around in the course of carrying out the normal operations and maintenance of the **boat when racing**.

Yaw : The movement of the **boat** about a vertical axis that passes through its centre of gravity.

A.3 AUTHORITY

WS has delegated the management of the International IMOCA Class to IMOCA.

IMOCA manages the CR.

A.4 MANAGEMENT OF THE CLASS

IMOCA's operating procedures are defined in its statutes and internal regulations which are published annually.

A.5 CLASS MEMBERSHIP

The skipper must be an active member of **IMOCA**.

A.6 CHANGES TO THE CLASS RULES

A.6(a) All changes to the CR must be approved by vote by members of IMOCA at a General Meeting.

A.6(b) Rule 87 of the RRS applies :

« The notice of race or the sailing instructions may change a class rule only when the class rules permit the change, or when written permission of the class association for the change is posted on the official noticeboard. »

A.6(c) Any change to the CR shall be subject to WS's approval.

A.6(d) Except in matters of extreme urgency, any change to the CR dealing with stability, or the fundamental structures of the **hull**, mast and hull appendages shall be made at a General Meeting that deals with the CR and which takes place in a « Vendée Globe » start year.

For the CR specific to crewed races, changes must be made at a General Meeting which takes place either in the year of the start, or at the latest, before the finish of the crewed round the world race.

A.6(e) Where a change to the CR entails high costs and/or significant technical modifications to existing **boats**, the grandfather rule, when described in APPENDIX A, exempts existing boats from complying with the new rule.

A.6(f) If an immediate change to the CR is required, the Executive Committee will decide how it is applied.

This change shall become permanent following approval by IMOCA members at the following General Meeting.

A.7 INTERPRETATIONS OF THE CLASS RULES

A.7.1 CLASS RULES COMMITTEE

A.7.1(a) The CRC comprises 3 people nominated by IMOCA's Executive Committee and approved by vote by members of IMOCA at the following General Meeting.

The composition of the CRC is described in APPENDIX F of the CR.

It is comprised, where possible, of :

- a person with no involvement in any project ;
- a naval architect not involved in an IMOCA project ;
- a WS representative specialising in rules and regulations.

A.7.1(b) The CRC's decisions are final and cannot be contested by an event jury, including an international jury, nor by any other course of action through a court or tribunal.

A.7.2 INTERPRETATION

A.7.2(a) CR interpretations shall be made by IMOCA who shall delegate the task to the CRC, who may issue an interpretation at its sole discretion.

A.7.2(b) Any request for interpretation of the CR shall be submitted in writing to the CM, who will pass it on to the CRC.

A.7.2(c) Requests for interpretation shall only be made by members of IMOCA or the CM.

A.7.2(d) All interpretations shall be made in writing as soon as possible and shall be posted on the IMOCA website.

A.7.2(e) The origin of a request for interpretation shall remain confidential.

A.7.2(f) The cost of a request for interpretation shall be set by IMOCA's Executive Committee.

A.8 BOAT MEASUREMENT AND INSPECTION

A.8.1 CHIEF MEASURER AND MEASURER

A.8.1(a) The CM, mandated by IMOCA, is responsible for issuing a MC, or suspending a MC for non-compliance with the CR.

A.8.1(b) The decisions of the CM may be submitted to the CRC for approval by means of a request for interpretation, but shall not be contested by an event jury, including an international jury, nor by any other course of action through a court or tribunal.

A.8.1(c) Only the CM and IMOCA-approved measurers are permitted to carry out the necessary inspections and tests required for a MC to be issued.

Their names and contact details are listed in APPENDIX F of the CR.

A.8.2 BOAT INSPECTION

A.8.2(a) All procedures, inspections, tests and measurement and calculation procedures required to obtain a MC are described in the measurement protocol.

A.8.2(b) The data, measurements, documents and information gathered by the CM and measurers in the process of issuing a MC are confidential.

A.8.2(c) The CM can request an inspection to be carried out on any **boat** at any time.

A.8.2(d) Data logged at sea shall be shared with IMOCA upon request.

The data is confidential ; it shall solely be used by IMOCA with the aim of improving and/or checking the safety and design of standardised items of equipment and parts.

A.8.3 KEEL INSPECTION

A.8.3(a) A keel shall undergo an NDT before its first launch.

A.8.3(b) A keel's NDT is valid for a maximum period of 4 years.

A.8.3(c) A keel's NDT must cover the entire period that the MC is valid, and is valid for just one race around the world.

A.8.3(d) The NDT report for a valid keel shall be submitted to the CM to obtain a MC.

A.8.4 MAST INSPECTION

A.8.4(a) A mast shall undergo an NDT before being used for the first time.

A.8.4(b) A mast's NDT is valid for a maximum period of 1 year.

A.8.4(c) An NDT report must be submitted to the CM to obtain a MC.

A.8.5 HULL INSPECTION

A.8.5(a) The **hull** shall undergo an NDT in the start year of a race around the world.

A.8.5(b) The **hull** NDT report must be submitted to the CM to obtain a MC.

A.8.6 DAMAGE REPORT

Following structural damage or damage to a standardised component (standardised mast, standardised boom, standardised canting system, standardised keel fin, standardised life raft), the skipper or their designated representative shall, as soon as possible, be available to the CM in order to provide it with any information concerning the circumstances of the damage – in particular raw data from recordings – the inspection of damaged components, the causes of the damage and any **modifications** and/or **repairs** carried out.

A.9 IMOCA MEASUREMENT CERTIFICATE

A.9.1 OBTAINING A MC

- A.9.1(a)** The MC is issued in the name of the **boat** and her skipper who must be a paid-up active member.
- A.9.1(b)** The skipper may designate a representative to follow all the tests and measurement operations as well as the administrative steps required to obtain a MC.
The skipper has sole responsibility for compliance with the CR, and for the compliance of his **boat** with the MC, and must sign the MC.
- A.9.1(c)** The costs relating to the various steps in the process for obtaining a MC are set by IMOCA's Executive Committee.
- A.9.1(d)** To obtain a MC, the **boat** shall undergo all the inspections and tests that the CM deems necessary.

A.9.2 MC VALIDITY

- A.9.2(a)** The MC is valid for the race{s} listed on the MC unless the CM modifies the period of validity.
- A.9.2(b)** A **boat** shall only hold one valid MC at a time. A new MC automatically invalidates the previous one.
- A.9.2(c)** The CM can declare an MC invalid at any time.
- A.9.2(d)** In the case of a change of skipper, the new skipper shall request a new MC.
- A.9.2(e)** Any **modification** or **repair** to the boat requires the MC to be renewed as described in CR **Erreur ! Source du renvoi introuvable.**

A.9.3 FIRST MC

- A.9.3(a)** To obtain the first MC for a new build, the skipper or the IMOCA member responsible for the build of the **boat** shall fill in the "new build declaration" form (see CR APPENDIX K-2) and submit it to the CM before work on the construction of the **hull** begins.
- A.9.3(b)** The CM and measurers shall have unlimited access to the **boat** during the entire build period.
- A.9.3(c)** The skipper or IMOCA member responsible for the **boat** build shall supply the CM with all the documents listed in CR APPENDIX K-3.

A.9.4 MC RENEWAL

The skipper shall fill in the form in APPENDIX K-4 of the CR, describing any **modifications** or **repairs** made to the **boat**, and submit it to the CM to issue a new MC.

A.9.5 ISSUING A MC FOLLOWING MODIFICATION TO THE BOAT

- A.9.5(a)** Any **modification** or **repair** to the **boat** after the date of issue of a MC shall be the subject of a written report submitted to the CM.
- A.9.5(b)** Any unreported **modification** or **repair** invalidates the MC.
- A.9.5(c)** The CM shall assess whether specific inspections and tests are required to issue a new MC.

A.10 DOCUMENT STORAGE

MOCA shall hold all the documents that it has consulted to issue a current MC. All documents held are confidential.

A.11 EXCEPTIONAL CASES

- A.11(a)** In the case of an unforeseen event and/or exceptional circumstances and/or in the context of sustainable development and/or the use or installation of renewable energy solutions which prevent the skipper from complying with one or more provisions of the CR, a skipper may request dispensation for one or several provisions of the CR in order to obtain a MC.
- A.11(b)** In the case of a request for dispensation for one or more provisions of the CR in order to obtain a MC, the skipper must submit to the CM in writing all the details in his possession along with a written waiver stating that there will be no claims by the skipper.
- The CM will submit a report to the President of IMOCA for his opinion.
- Maintaining sporting equity as well as the highest safety standards for the crew and **boat** shall take precedence.
- The CM will convey the decision after consultation with the President of IMOCA.
- A.11(c)** Decisions relating to dispensation regarding the application of one or more provisions in the CR in order to obtain a MC can be found on the website in the IMOCA "members" section at : <https://www.imoca.org/fr/docs-de-la-commission-technique>.

SECTION B ELIGIBILITY

B.1 CLASS RULES AND CERTIFICATION

- B.1(a)** Only a skipper in possession of a valid MC for his **boat** may *race*. He must comply with the CR at all times when *racing*.
- B.1(b)** In the case of damage during a race, a **boat** which no longer complies with the CR may finish the race.
Non-compliance with the CR must only be due to damage and shall not under any circumstances be advantageous to the skipper.
- B.1(c)** The **boat** shall have all the required certification marks, identification marks and all the required branding.

B.2 HULL AND SAIL NUMBERS

- B.2(a)** IMOCA allocates a **boat's** sail number.
- B.2(b)** A **hull** number allocated by the CM shall be moulded or engraved on the **boat's** transom.

CHAPTER II CONDITIONS AND RESTRICTIONS

SECTION C CONDITIONS FOR RACING

C.1 MOVABLE BALLAST

The second sentence of RRS Rule 51 is replaced as follows :

« Moving ballast with the purpose of changing trim or stability is permitted within the limits fixed by these rules :

- C.1(a)** Food supplies, drinks, equipment and stores which are not sealed and not permanently attached, may be moved when they are not being used for their primary purpose, on condition that once in place, these items be solidly fastened to the inside of the **hull**.
- C.1(b)** Sails not being used shall be either :
- (i) on a furler, hoisted and ready to be deployed ;
 - (ii) on the deck inside the working deck ;
 - (iii) inside the **hull**.

Sail bags shall not be watertight.

- C.1(c)** Movable hull appendages shall not be moved from their normal positions.
- C.1(d)** The principal items of safety equipment listed in CR **Erreur ! Source du renvoi introuvable.**, when not being used for their primary purpose, shall be permanently stowed according to the safety equipment location chart described in CR **Erreur ! Source du renvoi introuvable.**
- C.1(e)** The skipper shall only bring aboard what is reasonable and necessary for each race, and in no circumstances shall he bring aboard extra equipment and supplies whose purpose is to affect the stability of the boat. »

C.2 OUTSIDE HELP, SERVO POWER AND MANOEUVRING

C.2(a) RRS Rule 52 is replaced as follows :

« The boat's standing rigging, running rigging, sails, spars, and foils or daggerboards shall be adjusted and operated only by the power provided by the crew. Only the keel, rudders and the filling, transferring and emptying of the ballast tanks may be adjusted and operated by power provided by other sources. »

C.2(b) Servocontrol is expressly forbidden with the following exceptions :

- (i) adjustment and operation of the keel, and in the case of a standardised canting system, using solely the material and equipment supplied ;
- (ii) the rudders to affect yaw.

C.2(c) The crew's physical force alone shall be used to manoeuvre and trim the **boat**. This force shall not be accumulated in a storage system, even temporarily, before use.

C.2(d) *When racing, the skipper must not receive any :*

- (i) personalised weather assistance; remote routing is permitted but only via the platforms approved by IMOCA's sporting committee ;
- (ii) performance assistance ;
- (iii) remote intervention on any of the **boat**'s equipment ;
- (iv) personalised medical assistance from a third party without informing the race doctor ;
- (v) organised psychological assistance.

C.3 SAFETY EQUIPMENT

All material and equipment described in CR **Erreur ! Source du renvoi introuvable.** to **Erreur ! Source du renvoi introuvable.** inclusive, shall be :

- (a) on board ;
- (b) of solid construction ;
- (c) installed, remain in place and be easily accessible ;
- (d) securely stowed ;
- (e) functioning correctly and regularly serviced ;
- (f) inspected at intervals in accordance with the manufacturers' instructions ;
- (g) suitable for the number of crew on board, all of whom shall be instructed in its use.

C.3.1 SAFETY EQUIPMENT LOCATION CHART

A safety equipment location chart in durable waterproof material, displayed inside the **boat** near the companionway hatch(es), marked with the location of all items of safety equipment.

C.3.2 BILGE PUMPS AND BUCKETS

C.3.2(a) Two solid buckets, each with a lanyard, and of at least 9 litres capacity.

C.3.2(b) At least two electric bilge pumps, each with a minimum output of 2400 litres/hour. One of these two systems shall be permanently installed and remain in place.

- C.3.2(c)** One of the two systems described in CR C.3.2(b) shall enable emptying each watertight compartment from outside of it. The other one must be able to empty each watertight compartment.
- C.3.2(d)** The bilge pumps shall have a minimum rated capacity of 12000 litres/hour and may be combined to meet this requirement.

C.3.3 EMERGENCY DRINKING WATER

- C.3.3(a)** Emergency drinking water stored in one or several containers, which must be sealed
- C.3.3(b)** The container(s) must remain in place and it shall be possible to seal it/them in place.
- C.3.3(c)** The volume of water depends on the length of the race and the number of crew on board, and shall be defined in the Sailing Instructions for each race.

C.3.4 LIFERAFTS

- C.3.4(a)** Liferafts shall not be movable and shall be sealed in place.
- C.3.4(b)** The liferafts shall be :
- (i) One ISO 9650 compliant liferaft :
 - This liferaft shall be the standardised liferaft, accompanied by the grab bag detailed in the measurement protocol ;
 - This liferaft shall be on deck, aft of the companionway hatch(es), and easily launched. The centre of gravity of this liferaft in its container must be forward of point X=0 of the boat reference ;
 - It shall be packed in a rigid container ;
 - The end of the liferaft painter shall be permanently securely fastened to a solid attachment point on the **boat**.
 - (ii) A liferaft which complies with ISO 9650-1-A, PACK 2 (<24h) :
 - This liferaft shall be the standardised liferaft ;
 - This liferaft shall be stowed inside the boat ;
 - It must be able to fit through all watertight bulkhead openings giving access to all possible escape routes out of the boat, including the transom escape hatch.
- C.3.4(c)** For a crewed race, the liferafts required on board shall be defined in the Notice of Race.

C.3.5 MAN OVERBOARD RECOVERY

- C.3.5(a)** A lifebuoy marked with the **boat's** name within reach of the helmsman. This lifebuoy shall depend entirely on permanent buoyancy (e.g. foam), have marine grade retroreflective material on it and be equipped with a sachet of fluorescein dye, a whistle, a self-igniting light and a drogue.
- C.3.5(b)** A recovery sling which shall be of a minimum strength capable of hoisting a crew member aboard, and easily accessible from the cockpit. It shall include :
- (i) a buoyant line of no less than 36000 mm ;
 - (ii) a buoyancy sling (horseshoe) with no less than 90 N buoyancy.

- C.3.5(c)** A « Jonbuoy Mark V ou VI » type module with an AIS beacon included and which inflates automatically, shall be installed at the back of the **boat** on a rigid support.

C.3.6 LIFEJACKETS

- C.3.6(a)** One lifejacket per crew member – which complies with ISO 12402-3 (level 150) or equivalent, including EN 396 or UL 1180 – which shall :
- (i) be fitted with a whistle and marine grade retroreflective material ;
 - (ii) be compatible with wearing a safety harness ;
 - (iii) have a crotch/thigh strap ;
 - (iv) be clearly marked with the **boat's** name ;
 - (v) have an emergency position indicating light in accordance with ISO 12402-8 or SOLAS LSA code 2.2.3 ;
 - (vi) have a sprayhood in accordance with ISO 12402-8 ;
 - (vii) have a PLB unit as described in CR C.3.15(b), properly registered with the appropriate authority.
- C.3.6(b)** A spare gas cylinder for each lifejacket.
- C.3.6(c)** At least one spare lifejacket in accordance with CR C.3.6(a) without the equipment listed in CR C.3.6(a)(vii).

C.3.7 SAFETY HARNESS AND TETHERS

- C.3.7(a)** Each crew member shall have a harness and tether which complies with ISO 12401 or equivalent.
- C.3.7(b)** Each harness shall be equipped with a tether not exceeding 1000mm, including the length of the hooks at each end :
- (i) A 2000 mm long tether with a midpoint hook is permitted ;
 - (ii) The hooks shall be self-closing ;
 - (iii) The tethers shall have an overload indicator flag embedded in the stitching. A tether which has been overloaded shall be replaced.

C.3.8 PERSONAL SAFETY EQUIPMENT

Each crew member shall have on board and on his person as much as possible :

- (a) a sharp knife ;
- (b) a waterproof torch ;
- (c) a personal AIS beacon ;
- (d) on deck at night, a chemical light stick and a personal location light (SOLAS or strobe).

C.3.9 PERSONAL SURVIVAL EQUIPMENT

Each crew member shall have :

- (a) vacuum-packed warm clothes ;
- (b) an immersion suit including protection for the head, feet and hands, and which shall :
 - (i) have an immersed thermal insulation value without thermal underwear of more than 0.75 Clo ;

- (ii) be stowed in a bag attached near the companionway(s) (less than 1500 mm from the centre of the hatch).

C.3.10 COCKPIT KNIFE

A strong, sharp knife, sheathed, and securely restrained, readily accessible from the deck or a cockpit.

C.3.11 SOFT WOOD PLUGS

Tapered soft wood plugs of the appropriate size shall be permanently stowed adjacent to every through-hull opening.

C.3.12 FIRE FIGHTING EQUIPMENT

C.3.12(a) At least two fire extinguishers of at least 2 kg each, and for dealing with A, B and C type fires.

They must be readily accessible :

- (i) one fire extinguisher shall be near the engine ;
- (ii) the other fire extinguisher shall be near the companionway(s) (less than 1500 mm from the centre of the hatch).

C.3.12(b) A fire blanket adjacent to the cooking device.

C.3.13 SPARE

C.3.14 RADAR

C.3.14(a) A pulse radar of a minimum of 2 KW PEP or a Broadband type radar. It shall be equipped with :

- (i) the means of programming to automatically scan at set intervals ;
- (ii) an external alarm on deck and/or in the cockpit(s).

C.3.14(b) The radar antenna unit shall be at least 5000 mm above the boat reference XY plane, and weigh at least 5.5 kg.

C.3.15 EPIRBs

C.3.15(a) Two water and manually activated portable COSPAS-SARSAT EPIRBs, with a long battery life (minimum 48 hours continuous transmission).

These beacons shall be :

- (i) installed in a highly visible location and immediately accessible near the companionway(s) ;
- (ii) dual frequency (406 MHz and 121.5 MHz) and equipped with a GPS ;
- (iii) coded and registered in the **boat's** name with the relevant MMSI number ;
- (iv) solidly attached to a line at least 3000 mm long and of a minimum breaking strain of 1000 kg ;
- (v) feature on the safety equipment location chart (see CR C.3.1).

C.3.15(b) One dual-frequency personal location beacon (PLB) (121.5 MHz and 406 MHz) per crew member.

C.3.16 EMERGENCY TRANSMISSION

At least one through-hull fitting through which the following can be installed when the **hull** is inverted at 180 degrees :

- (a) a VHF antenna ;
- (b) a Cospas-Sarsat beacon antenna or any other positioning beacon antenna ;
- (c) an iridium satellite telephone antenna.

C.3.17 DROGUE

A drogue suitable for an IMOCA and certified by IMOCA, it shall have a minimum diameter of 60 cm.

C.3.18 FIRST AID KIT

C.3.18(a) The contents of the First Aid Kit shall comply with the recommendations in the onboard manual or the current FFVoile Medical Rules.

The contents of the First Aid Kit shall reflect the type of race and the number of crew.

C.3.18(b) The First Aid Kit shall include the latest edition of one of the following manuals :

- International Medical Guide for Ships, World Health Organization, Geneva;
- First Aid at Sea by Douglas Justins and Colin Berry, published by Adlard Coles Nautical in London ;
- Le Guide de la Médecine à distance, by Dr JY Chauve, published by Distance Assistance BP33 – La Baule Cedex France (an English translation is available) ;
- Skippers’s Medical Emergency Handbook, First Aid at Sea, by Dr Briggs and Dr Mackenzie, published by Adlard Coles Nautical in London ;
- Guide médical de bord de Jean-Marc Le Gac - Editions Vagnon ;
- Another manual in the skipper’s language, approved by the CM.

C.3.18(c) An emergency First Aid Kit prepared by the skipper, shall content at least a tourniquet, codeine paracetamol, injectable adrenaline and prednisone 20 mgs. This kit shall be located in a fixed location near the companionway(s) (less than 1500 mm from the centre of the hatch), readily and quickly accessible.

C.3.19 DIVING EQUIPMENT

C.3.19(a) One “Spare Air” dive tank or equivalent with a minimum volume of 80 litres.

C.3.19(b) A diving suit to cover the entire body, together with gloves, fins and a mask.

C.3.20 WATERPROOF EMERGENCY CONTAINER

C.3.20(a) A waterproof emergency container (or backpack), equipped with strong handles and a line with a minimum breaking strain of 1000 kg, which shall :

- (i) have inherent flotation ;
- (ii) have at least 0.10 m² of fluorescent orange colour on the outside ;
- (iii) be marked on the outside with the name of the **boat** ;
- (iv) be attached and remain in its location near the companionway(s) (at less than 1500 mm from the centre of the hatch).

C.3.20(b) This container shall contain at least :

- (i) a waterproof handheld VHF with charged spare batteries ;
- (ii) a handheld Iridium telephone, waterproof or with a waterproof cover with charged spare batteries ;
- (iii) a waterproof handheld GPS with spare batteries ;
- (iv) a waterproof torch with batteries ;
- (v) a knife ;
- (vi) several chemical light sticks ;
- (vii) several sachets of sea marker dye (fluorescein) ;
- (viii) one personal location light (SOLAS or strobe) with spare batteries per crew member ;
- (ix) 4 red hand flares and 2 orange smoke flares in accordance with SOLAS LSA Code Chapter III relating to Visual Signals ;
- (x) several packs of high-energy food of at least a combined total value of 10000 KJ ;
- (xi) one survival blanket per crew member.

C.3.21 ANCHORS AND TOWING WARPS

C.3.21(a) Two sets of anchoring equipment. Each set shall :

- (i) include an anchor, chain and a 50000 mm long pre-stretched 18 mm polyamide warp – this warp shall be used as an anchor warp or a towing warp ;
- (ii) be sealed in the same location with its own warp ;
- (iii) be able to be readied on deck in less than 3 minutes by the skipper alone.

C.3.21(b) The total weight of both sets of anchoring equipment without their warps shall be at least 75 kg.

C.3.22 TORCHES

C.3.22(a) A watertight torch or high-intensity searchlight with integral strobe light.

It must be rechargeable or have spare batteries.

C.3.22(b) One watertight torch with integral strobe light, with spare batteries and bulbs, per crew member.

C.3.23 TOOLS AND SPARE PARTS

Tools and spare parts, including the means to quickly disconnect the standing rigging from the **hull**.

C.3.24 EMERGENCY TILLER

An emergency tiller shall be on board.

C.3.25 PROTECTION

One protective helmet per crew member.

C.3.26 ANTI-SMOKE MASK

A respiratory protection mask against smoke shall be on board and located near the companion way.

C.4 MEDICAL AND SURVIVAL TRAINING

These training courses are highly recommended for all crew members.

- C.4(a)** Before the start of a race, the skipper (and co-skipper for double-handed races) shall have :
- (i) undertaken appropriate medical training at least once in the previous five years for the type of race to be sailed ;
 - (ii) undertaken WS-approved offshore personal survival training at least once in the previous five years.
- C.4(b)** IMOCA periodically organises training for skippers and co-skippers on the techniques and rescue methods and safety at sea.
- Skippers and co-skippers are required to participate unless they have written dispensation from IMOCA's Executive Committee.

C.5 ADVERTISING

- C.5(a)** The skipper is permitted to display advertising on the **boat** under his responsibility.
- C.5(b)** A circle of 3000 mm diameter situated in the lower third of both sides of the mainsail and above the 1st reef, or an area of a maximum surface area of 7.0 m² to be defined, shall be free of all advertising.
- This space shall be reserved for potential promotional branding for race organisers when approved by IMOCA.
- C.5(c)** The official logo or the IMOCA sponsor logo or IMOCA class insignia or the championship logo, shall be displayed on both sides of the top of the mainsail, as well as on one sleeve of the skipper's and team members' technical clothing.
- C.5(d)** Depending on the agreement between IMOCA and an event organiser, one or some dodgers featuring promotional branding for IMOCA and/or the event organiser, shall be displayed on each side :
- (i) in port, at the start and at the finish of the race ;
 - (ii) tautly attached at the back of the lateral lifelines.
- C.5(e)** The branding guidelines are described in CR APPENDIX E.
- C.5(f)** A maximum surface area of 1.0 m² on the **boat** shall be made available to IMOCA to be able to display technical partners or partners associated with sustainable development.
- C.5(g)** In-port promotional sails shall comply with CR APPENDIX E.

C.6 ENERGY / ENGINE

C.6.1 ENGINE / GENERATOR

- C.6.1(a)** General remarks :
- (i) An engine or generator shall be :
 - diesel ;
 - permanently and safely installed and protected ;
 - affixed to the **boat** and remain in place.

- (ii) An engine or generator shall not be :
 - used when *racing* to move the **boat** ;
 - be moved within the **boat**.
- (iii) All or part of an engine's equipment and its propulsion system shall have a means of being sealed *when racing* in order to ensure that the engine cannot propel the **boat**.

C.6.1(b) The "main" engine shall be installed for the purpose of propelling the **boat**, and it shall meet the following performance standards at all times :

- a traction load of 330 daN at a fixed point for 15 minutes ;
- a speed of 5.0 knots in any direction with a proven autonomy of 5 hours.

These characteristics shall be capable of being checked at the finish of a race.

C.6.1(c) For a diesel engine or generator :

- (i) The exhaust, cooling system and fuel system shall be permanently installed ;
- (ii) All required fuel shall be contained in fuel tanks which shall remain in place ;
- (iii) Fuel tanks shall be permanently and securely installed and protected ;
- (iv) It must be possible to close each fuel tank ;
- (v) Transferring between fuel tanks is strictly forbidden. The use of a "day" tank, of a volume less than or equal to 10 litres, installed near the "main" engine is exempt from this proscription ;
- (vi) If used as the "main" engine, the diesel engine shall have a "manufacturer's" power output of at least 45 hp and, unless written dispensation has been granted by the CM, shall be selected from the following list of commercial products : Yanmar 4JH45, Nanni N4.50, Volvo D2.50 Lombardini KDI 2504M MT, Solé Marine Mini 55, Vetus M4.56 ;
- (vii) Hybrid electric engines may be authorised by the CM if they meet the speed, power and range criteria ;
- (viii) The integral components of the "main" engine shall not be removed or modified, with the exception of electrical wiring as well as alternators and their mounts and pulleys, which may be modified.

C.6.1(d) The "main" engine control system(s) which control(s) "forward" and/or "reverse" (gearbox) shall be accessible from the on-deck helming position and it shall be possible to seal it/them).

C.6.1(e) The "main" engine propeller :

- (i) shall be positioned below the boat reference XY plane ;
- (ii) shall not be retractable ;
- (iii) shall not be installed on a hull appendage ;
- (iv) shall be more than 1500 mm from the transom.

C.6.1(f) A fuel reserve of 60 litres, subject to penalties, for emergency use of the propulsion engine or diesel generator shall be stored in an independent tank(s) system, sealed during filling and use, and approved by the CM before being installed on the **boat**.

This emergency fuel reserve shall :

- (i) comply with CR C.6.1(c) ;
- (ii) be permanently installed and connected with a valve which must be able to be sealed in the closed position ;
- (iii) be ready for use.

When measuring and filling the tank(s), the fuel shall be at ambient temperature and pressure.

C.6.1(g) The maximal fuel quantity free used on board *when racing* is 60 litres.

This fuel shall be stored in a system of no more than three tanks with a maximum combined capacity of 60 litres, sealed when filled, approved by the CM before being installed on the **boat**.

When measuring and filling the tank(s), the fuel shall be at ambient temperature and pressure.

The fuel reserve mentioned in C.6.1(f) is not included in this maximal fuel quantity.

C.6.2 BATTERIES

C.6.2(a) The batteries shall not be moved at sea and shall :

- (i) be waterproof or gel electrolyte type ;
- (ii) remain attached and in place no matter what the position of the **boat** ;
- (iii) be capable of being sealed in position.

C.6.2(b) When an electric starter motor is used to start the “main” engine, it shall have a separate battery or electrical source with an independent charging system, the primary purpose of which is to start the engine.

C.6.2(c) Any system using fissile materials, as well as acid-based batteries, is strictly forbidden on board, be it for the production or storage of energy.

C.6.2(d) Batteries shall be of commercial production and shall not be modified.

C.6.3 BATTERIES WATERTIGHTNESS

C.6.3(a) In the case of non-gel batteries :

Batteries and/or battery bank shall be watertight to at least IPX7 or IPX2 if installed in an immersion-proof container to 1000mm.

A watertight container up to 1000mm, with a ventilation system whose opening is located at a height of more than 1100mm from the waterline is permitted.

C.6.3(b) Exception for batteries installed before 1 January 2024 :

Batteries and/or battery bank shall :

- (i) be watertight to at least IPX5 in the case of any other technology than LFP ;
- (ii) or be watertight to at least IPX2 in case of LFP technology battery.

C.6.4 INSTALLATION OF ALL LITHIUM TYPE BATTERIES

Lithium batteries shall be permanently connected to the BMS switchgear. They shall be installed in a safe and suitable manner in accordance with the manufacturer's safety requirements for all aspects of use, including disconnection in the event of :

- overheating ;
- overcurrent ;
- low or high voltage limit.

If an external BMS is used, it must comply with C.6.3 or be installed in a watertight container that protects against high water jets from all directions.

C.6.5 FUEL

The only types of fuel expressly permitted on board are :

- diesel fuel and its synthetic derivatives for an engine, a generator and/or a heating system ;
- gas for cooking and safety equipment.

C.7 NAVIGATION

C.7.1 COMPASS

C.7.1(a) Un compas magnétique de type « marine » doit être installé, resté en place, indépendant de toute source électrique, compensé et accompagné de sa courbe de compensation.

C.7.1(b) Un compas supplémentaire à celui ci-dessus doit être à bord.

C.7.2 NAVIGATION EQUIPMENT

Shall be installed and in working order :

- (a) a 25 W DSC capable marine VHF transceiver, equipped with a fixed antenna ;
- (b) an active AIS and navigational software that displays AIS targets and a masthead antenna ;
 - (i) A certificate of conformity for the AIS installation dated less than a year old shall be submitted to the CM to obtain a MC. The details are described in the measurement protocol ;
 - (ii) The AIS shall be Class A or Class B+ ;
- (c) a watertight handheld VHF radio ;
- (d) an emergency VHF/AIS antenna ;
- (e) two satellites communication systems, fixed and in working order including :
 - (i) a system using a satellite network supporting the GMDSS protocol and having a minimum upload rate of 20 kbps ;
 - (ii) a communication system having a minimal upload rate of 250 kbps ;
- (f) a GPS ;
- (g) a « YB3i Tracker » connected to the service battery ;
- (h) a depth sounder ;
- (i) a **boat** speed measuring device.

C.7.3 NAVIGATION DOCUMENTS

Navigational charts, not solely electronic, and light lists for the geographic zones covered by the race, along with chart plotting equipment, shall be on board.

C.8 IDENTIFICATION

C.8(a) To assist with identification at sea, the sail number shall be inscribed once on the deck and shall be highly visible.

The dimensions of the numbers shall be at least as follows :

- Height : 900 mm ;
- Width : 600 mm ;
- Thickness : 120 mm ;
- Gap between numbers : 180 mm.

C.8(b) A corresponding indoor/outdoor area of the hull which can be easily destroyed to enable evacuation of the crew shall be marked with highly visible paint on the exterior and interior of the **hull**.

C.8(c) A brightly coloured and highly visible paint shall be applied to the entire surface of :

- the keel ;
- the rudders ;

and on the exterior, in a single surface area of at least 2.0 m² :

- the **hull** shell beneath the waterline ;
- the deck.

C.9 BOAT : FITTINGS AND EQUIPMENT

C.9.1 WORKING DECK

C.9.1(a) The ISO 15085 (design category A) standard – applies as a minimum and is supplemented or replaced by the following specifications up to CR **Erreur ! Source du renvoi introuvable.** inclusive.

C.9.1(b) The areas of the working deck at the stanchion and pulpit bases, other than the exception specified CR **Erreur ! Source du renvoi introuvable.**(i) shall be :

- (i) inside the **sheerline** and a straight line through the aftermost points on the **sheerline** each side of the **boat** ;
- (ii) within a limit situated less than 500 mm inside the projection of the **sheerline** on the boat reference XY.

C.9.1(c) The measurement protocol describes the method for measuring the **sheerline**.

C.9.2 PULPITS, STANCHIONS AND LIFELINES

C.9.2(a) General principles

- (i) The pulpits, stanchions, lifelines and guard rails shall :
 - render the working deck safe in a permanent manner ;
 - have their attachment points positioned within the hull length; attaching the pulpit mounts to the forward spar is expressly permitted ;
 - be a minimum height above the working deck of :
 - o 600 mm ;
 - o 800 mm in the case of a cockpit which finishes at the back of the **hull**.
- (ii) There shall be at least two lifelines surrounding the working deck.
- (iii) It shall be demonstrated to the CM that the pulpits, stanchions, lifelines and guard rails enable the crew member(s) to work safely within the confines of the working deck.
- (iv) The **boat** shall have a pulpit and stanchion in stainless steel, with a minimum wall thickness of 1,5 mm. The minimum diameter of stanchions shall be 30 mm except at their upper end, and 25 mm for pulpit. The **boats** which obtained their MC before 15th October 2020, having stanchions in stainless steel with a minimum diameter of 28 mm are authorized to keep them.
- (v) Stanchions shall be angled to not more than 10 degrees with the exception of **CR Erreur ! Source du renvoi introuvable.**(v).

C.9.2(b) Pulpit

- (i) The **boat** shall have a pulpit of tubular one-piece construction.
- (ii) The pulpit shall have at least 4 structural attachment points.
- (iii) The pulpit shall enclose all forestays whose attachment point is situated on the deck of the boat.
- (iv) The opening between the pulpit and any part of the boat must not exceed 380 mm with the exception of the bow pulpit which can be open on condition that the opening does not exceed 500 mm and is situated at a height of at least 300 mm.
- (v) Lifelines through suitably-adapted stanchions across the stern may replace a stern pulpit.

C.9.2(c) Lifelines

- (i) All lifelines shall be :
 - permanently in place and correctly tensioned ;
 - supported exclusively by the pulpit, pushpits and stanchions at intervals of not more than 2200 mm ;
 - of SK core and cover over their entire length with a minimum external diameter of 6 mm.
- (ii) All lashings, components and attachment points that make up the lifeline system shall have a breaking strain greater than the lifeline itself.

- (iii) The vertical openings between 2 lifelines shall be less than 380 mm, and the opening between the deck and the lifeline shall be less than 300 mm.

C.9.3 JACKSTAYS / CLIPPING POINTS

C.9.3(a) General remarks

Jackstays and clipping points shall enable :

- a crewmember to clip on before coming on deck from inside the **boat** and to unclip after going below ;
- to move readily between the working areas on deck and the cockpit(s) whilst remaining clipped on, including being able to cross the deck from one side to the other, with the minimum of clipping and unclipping operations.

The clipping points shall enable two crew members to be simultaneously clipped on without depending on the jackstays.

Particular care should be taken regarding the use of U bolts as clipping points, as they can lead to the accidental opening of some snaphook models.

C.9.3(b) Jackstays shall be :

- permanently installed along the deck to port and starboard of the centreline ;
- solidly attached to the deck ;
- webbing or SK rope with a minimum breaking strain of 20 kN (kilonewton) or greater.

C.9.3(c) Clipping points shall be strongly mounted, adjacent to stations such as the helm, the winches, the mast and anywhere where the crew work for long periods of time.

C.9.4 TOE RAIL / FOOT-STOP

A toe rail of minimum height of 30 mm shall be permanently installed around the working deck except where there are deck fittings and directly above the transom.

The toe rail shall be located as close as possible to the stanchion bases.

C.9.5 HAND HOLDS

C.9.5(a) The **boat** shall be fitted with adequate hand holds below deck and on deck so that crew members can safely move around the boat.

C.9.5(b) A suitable system permanently attached along the full length of the scoop, or the **hull** shell - transom intersection, and shall enable a crew member who has fallen overboard to hold on and climb back on board.

C.9.6 NAVIGATION LIGHTS

C.9.6(a) Navigation lights shall comply the IRPCAS rules relating to sailing vessels and also when the **boat** is underway under engine power or at anchor.

C.9.6(b) Navigation lights shall be mounted :

- so that they will not be masked by the sails or the heeling of the boat ;
- above deck level and at least at the height of the lower lifeline.

C.9.6(c) The reserve navigation lights shall :

- (i) have the same specifications as the navigation lights above ;
- (ii) be permanently installed ;
- (iii) have an independent wiring circuit to that of the primary navigation lights ;
- (iv) be mounted in a different location to the primary system and not be moved.

C.9.6(d) An anchor light shall be permanently installed.

C.9.6(e) A “flash light” at the top of the mast.

C.9.7 SEA COCKS AND VALVES / THROUGH-HULLS

Valves ($\frac{1}{4}$ turn or gate) or watertight sea cocks and their control systems shall be permanently installed on all through-**hull** openings below the boat reference XY plane, logs, depth sounders and other similar equipment.

C.9.8 HELM

The helm must allow the crew to steer manually (hydraulically or mechanically) in complete safety and without any energy other than that of the crew.

C.9.9 VISIBILITY

From the helm station, in measurement trim, the crew's horizontal field of vision must be direct and 360°.

C.10 BOAT : LIFE ON BOARD

C.10.1 BUNKS

C.10.1(a) One or several bunks shall be permanently installed on board.

C.10.1(b) The minimum number of bunks on board is calculated by taking the number of crew on board, divided by 2 and rounded up.

C.10.1(c) Each bunk shall be suitable for the height and weight of the crew members.

C.10.2 COOKING FACILITIES

A cooking stove, securely installed, permanently accessible, and with an accessible fuel shutoff control which can be safely operated at sea.

C.10.3 DRINKING WATER

C.10.3(a) The skipper is responsible for the quantity of drinking water to be embarked for the duration of the race and the number of crew.

C.10.3(b) Two commercially produced watermakers are mandatory on board. Each watermaker must have a nominal capacity at 20°C of at least 5 litres per hour. At least one of them shall operate both manually and electrically. The latter shall be installed on board and remain in place. The second shall operate electrically, at least.

C.10.4 TOILET

A basic sanitary facility shall be installed in a fixed position on board.

C.11 HYDRAULIC SYSTEMS

No hydraulic system shall be on board, with the exception of :

- the keel canting system ;
- the second degree of freedom adjustment for the foils ;
- the trim of headsails tack points and the cunningham ;
- rudder trim to affect yaw.

C.12 IDENTIFICATION ON SAILS

RRS 77 and G.1.1 are changed as follows :

« The display of letters and numbers on the mainsail, spinnaker and headsail is optional. »

SECTION D HULL

D.1 FUNDAMENTAL RULES

D.1(a) The **boat** shall be a monohull equipped with :

- (i) a standardised keel fin ;
- (ii) a standardised canting system ;
- (iii) one standardised mast ;
- (iv) a standardised boom.

D.1(b) The boat shall be symmetrical about the median XZ vertical plane of the boat reference.

D.1(c) The **boat** shall be designed, built and maintained to compete in transoceanic races and round the world races.

D.1(d) The **boat** shall have :

- (i) been designed, built and maintained to conform to the provisions of ISO 12215 Category A, as approved by the ISO WG18 authority.
The list of modifications is available in the IMOCA “members” section of the website at : <https://www.imoca.org/en/login> ;
- (ii) obtained a certificate of compliance of the construction drawings of the IMOCA as per CR D.1(d)(i), issued by the **boat**'s designer ;
- (iii) obtained a declaration, signed and dated by the **boat** builder, stating that he complied with the drawings checked by the designer.

D.2 DIMENSIONS

D.2(a) The hull length shall be a minimum of 17983 mm and a maximum of 18288 mm (60 feet).

D.2(b) LOA shall be a maximum of 20117 mm (66 feet). When the mast rake is between 4.0 and 6.0 degrees, it is specifically permitted for the boom to have a maximum of 25 mm overhang aft.

D.2(c) The beam of the **hull** in the boat reference shall not exceed 5850 mm.

D.2(d) The beam of the **hull** section on the boat reference YZ plane, 1000 mm aft of the forwardmost point used to determine the hull length, shall not exceed 1120 mm.

- D.2(e)** The curve, obtained by projecting on the boat reference XY plane the points whose coordinates in Y for each transverse section of the **hull** are greatest, shall not produce an inverted curve between the forwardmost point (used to determine the hull length) and the transverse section of the **hull** at Bmax.
- D.2(f)** The freeboard of the boat in the boat reference shall have a minimum height of 1550 mm forward and 1050 mm aft at the **sheerline** on the **hull**, and over a length greater than 1000 mm.

D.3 HULL MATERIAL LIMITATIONS

The **hull**, and the hull appendages, excluding associated fittings, shall be built in compliance with CR APPENDIX G.

D.4 BUOYANCY

- D.4(a)** The **boat** shall have a total buoyancy volume equal to or greater than 110% of the **boat's** displacement in measurement trim.
- D.4(b)** The calculation for this volume is described in the measurement protocol.

D.5 STABILITY AND RIGHTING MOMENT LIMITS

D.5.1 GENERAL REMARKS

- D.5.1(a)** IMOCA, under the authority of the CM, shall determine the theoretical stability curve for different configurations of the **boat** in measurement trim using the measurements taken during the stability tests, the information provided by the skipper and the measurements taken by the measurers to verify the different stability criteria described in CR **Erreur ! Source du renvoi introuvable.**, **Erreur ! Source du renvoi introuvable.** and **Erreur ! Source du renvoi introuvable.**
- D.5.1(b)** The conditions, the methodology, the procedure for the different stability tests, the calculations and measurements to be done are described in the measurement protocol.

D.5.2 AVS WORST CASE (AVSwc)

- D.5.2(a)** To calculate the AVSwc, the **boat** shall be considered to be in measurement trim with :
- (i) all the ballast tank combinations on the same side filled, including central ballast tanks if any ;
 - (ii) the keel fully canted on the same side ;
 - (iii) equipment and the movable hull appendages in the most unfavourable configuration ;
 - (iv) and without taking into consideration the buoyancy of spars.
- D.5.2(b)** With the **boat** in the least favourable configuration described in CR D.5.2(a), the AVSwc value shall be equal to or greater than 110 degrees.

D.5.3 MAXIMUM RIGHTING MOMENT

- D.5.3(a)** To calculate the maximum RM, the **boat** shall be considered to be in measurement trim with :

- (i) all the ballast tank combinations on the same side filled, including central ballast tanks if any ;
- (ii) the keel fully canted on the same side ;
- (iii) equipment and the movable hull appendages in the most unfavourable configuration.

D.5.3(b) With the **boat** in the configuration described in CR D.5.3(a), the RM shall be less than or equal to 25.5 TM (tonne metre) at 25.0 degrees of heel.

D.5.4 SELF-RIGHTING

D.5.4(a) For the numerically calculated 180 degrees self-righting test, the **boat** with the keel fully canted and the foils symmetrically retracted as far as possible, shall be considered to be in measurement trim but without: the standardised mast, the standing rigging and the boom.

D.5.4(b) When in the configuration described in CR D.5.4(a), the **boat** shall right itself from an inverted position of 180 degrees.

D.6 WATER BALLAST

D.6(a) A ballast tank shall only be filled with sea water to the exclusion of any other liquid.

D.6(b) The maximum number of ballast tanks is 4.

D.6(c) The ballast tanks shall be positioned symmetrically inside the **hull**.

D.6(d) All associated equipment (plumbing / valves / scoops /...) shall be permanently installed and not be moved.

D.6(e) Water shall be able to freely circulate inside each ballast tank and shall be able to reach the lowest point of the ballast tank.

D.6(f) Each ballast tank shall have an inspection hatch capable of being opened to reach the lowest point of the ballast tank.

D.7 COCKPIT

D.7(a) The ISO 11812 Standard (Quick-draining, self-draining cockpit, Design Category A) applies in measurement trim.

D.7(b) A semi-permanent washboard is permitted and it shall only open outwards.

D.7(c) With reference to ISO 11812, the **boat** shall have obtained from the designer a declaration of conformity with CR D.7(a) & D.7(b) which certifies that « the cockpit is quickly self-draining ».

D.8 WATERTIGHT COMPARTMENTS

For the application of CR D.8 and CR **Erreur ! Source du renvoi introuvable.**, refer to the report of the study undertaken by Bureau Veritas on the pressure generated by the sloshing of a liquid inside a compartment.

This report is available in the "member" section of the IMOCA website at : <https://www.imoca.org/en/imoca/official-documents>.

D.8.1 WATERTIGHT BULKHEADS

- D.8.1(a)** The required watertight bulkheads shall be built in such a way as to withstand direct water pressure without the slightest water ingress into the neighbouring compartment.
- D.8.1(b)** A watertight bulkhead shall be transverse.
- D.8.1(c)** The minimum number of watertight bulkheads is 5, making 6 watertight compartments.
- D.8.1(d)** No 2 watertight bulkheads, including any part of them, shall be separated by more than 5000 mm.
- D.8.1(e)** The forwardmost watertight bulkhead shall be less than 2740 mm from the forwardmost point of the **hull** in the boat reference.
- D.8.1(f)** A “solid structure to limit water flooding in” shall be installed around the area where the foil passes through the **hull** shell and shall be at a height of at least 500 mm above the boat reference XY plane.
- D.8.1(g)** A “solid structure to limit water flooding in” shall be installed around the areas where the keel bearings are attached to the **hull**.

D.8.2 WATERTIGHT BULKHEAD HATCHES

- D.8.2(a)** The **boat** shall be capable of being inspected from bow to stern by passing through the watertight bulkhead hatches and without leaving the watertight compartments, no matter what the position of the **boat**.
- D.8.2(b)** If they are not permanently installed, the watertight bulkhead hatches shall be stowed as close as possible to the relevant openings and able to be quickly put in place.
- D.8.2(c)** The hatches and their closing mechanism shall be able to withstand the pressure generated by the water in a flooded compartment.

D.9 HATCHES AND EMERGENCY EXITS**D.9.1 EMERGENCY EXITS**

- D.9.1(a)** The **boat** shall have at least two emergency exits :
- (i) with a minimum opening of 0.20 m² and of a geometry allowing the “interior” liferaft and the crew in survival suits to pass through them ;
 - (ii) that are equipped with a solid and watertight closing mechanism with handles on the interior and the exterior, which also operate the locking mechanism if there is one ;
 - (iii) that are capable of withstanding water pressure, regardless of the sea state and the attitude of the **boat**.
- D.9.1(b)** At least one emergency exit shall be located forward of the mast.
- D.9.1(c)** At least one emergency exit shall be entirely within 500 mm of the aftermost point of the **hull** in the boat reference.

This emergency exit shall be above the boat reference XY plane, so that the crew can enter and exit the **boat** regardless of the angle of heel anywhere between 0 and 180 degrees.

D.9.2 COMPANIONWAY HATCH

The companionway hatch(es) shall be equipped with a solid, watertight closing mechanism, operable by one person alone both from the exterior and the interior.

D.9.3 HATCHES

D.9.3(a) No hatches shall open towards the interior of the **hull** (except hatches with a surface area of less than 0.071 m²).

D.9.3(b) Hatches shall be positioned such that they are always above the boat reference XY plane when the **hull** is heeled to 90 degrees.

They shall be permanently installed and remain in place, capable of being shut immediately and remain shut regardless of the sea state or the attitude of the **boat**.

D.9.3(c) The hatches, closing mechanism and associated equipment shall be capable of withstanding water pressure when the **boat** is inverted.

SECTION E HULL APPENDAGES

E.1 GENERAL REMARKS

E.1(a) Any appendage on the hull shall be a hull appendage and shall be : a keel, a rudder, a foil.

E.1(b) The maximum number of appendages of hull is 5.

E.1(c) A hull appendage shall not present properties whose size and shape could allow it to be considered a **hull**.

E.1(d) Other than exceptions for the application of CR E.4(i), no combined motion (helical motion, etc.) is permitted for any hull appendage.

E.1(e) Flaps and deformable surfaces are expressly forbidden on hull appendages.

Deformations of a hull appendage under load and on which no trim can be exerted are exempt from this limitation.

E.1(f) The foil housing shall not open into the inside of the **hull**, with the exception of the watertight inspection hatches whose openings shall be entirely above the boat reference XY plane.

E.1(g) Materials whose density is greater than 11.4 are expressly forbidden in hull appendages.

E.1(h) The draught shall not exceed 4500 mm in measurement trim.

E.1(i) All hull appendages shall have an identification mark placed on them by the CM and the hull appendages other than the keel, shall conform to CR APPENDIX G.

E.2 KEEL

- E.2(a)** The standardised keel fin and the standardised canting system shall comply with CR APPENDIX B.

They shall not be modified with the exception of the fairing which can be locally modified at the keel-bulb join and/or near the **hull** shell.

The installation of hydrogenerator(s) approved by the CM on the standardised keel fin is permitted, subject to the CM's approval.

- E.2(b)** The system for attaching and assembling all the different elements which make up the standardised keel fin and the standardised canting system shall comply with CR APPENDIX B.

- E.2(c)** The longitudinal angle of the rotational axis of the keel shall be between 4.0 and 9.0 degrees in relation to the boat reference XY plane.

- E.2(d)** The keel shall have only one degree of freedom.

- E.2(e)** The lateral angle the keel may rotate around its axis shall be a maximum of 38 degrees on each side.

Appropriate mechanical stops shall be installed on each side and sealed, in order to limit the keel to the angle used in the stability calculations.

In the case of a mechanical stop in the ram, proof shall be provided (drawing, measurements taken by the measurer prior to installation, etc.).

A hydraulic and/or electrical cut-off does not constitute a stop.

- E.2(f)** The keel shall be able to be :

- (i) manually operated from the interior, regardless of the attitude of the **boat** ;
- (ii) locked in the middle using the safety system supplied with the standardised canting system.

- E.2(g)** For technical reasons associated with the correct functioning of the keel, the definition of a monohull can be waived in the area surrounding the keel-hull shell junction.

This area is limited in width to 500 mm overall, from one side to the other, and to a maximum depth of 40 mm above the projected fair surface of the **hull** shell, extended if necessary, as shown in the diagram below.

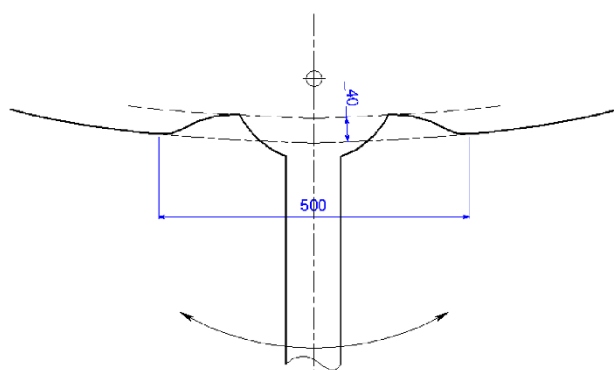

- E.2(h)** To safely use this equipment, the skipper shall follow the instructions for the standardised keel fin and the standardised canting system as provided in Note 1 supplied by the manufacturer at the time of delivery.

- E.2(i)** The keel shall not be equipped with appendages or any other equipment or system which could provide lift and/or affect the righting moment, leeway, stability and elevation.

E.3 BULB

- E.3(a)** The **boat** shall have just one bulb attached in one position to the standardised keel fin.
The bulb shall conform to CR APPENDIX B.
- E.3(b)** The installation of the standardised keel fin in the bulb shall conform to CR APPENDIX B.
The centre of gravity of the bulb shall be forward of the torsional axis of the standardised keel fin.
The bolts used to attach the bulb on the keel fin shall be of high tensile stainless steel of 17.4 PH or equivalent.
- E.3(c)** The weight of the bulb shall be between 2200 and 2850 kg.

E.4 FOIL

- E.4(a)** There shall be 2 foils to constitute a pair. The maximum number of foils with which a **boat** can sail during the application period of the CR is defined in CR APPENDIX O.
- E.4(b)** The foil shall be a solid structural unit; its geometry shall be a single continuous surface at all points. The foil section shall be a continuous closed contour, excluding the hardware associated with the degrees of freedom. All or part of a foil form of a T shape and/or Y shape and/or similar is expressly prohibited.
- E.4(c)** A foil shall comply with the following maximum limits :
- (i) a static moment of 8.00 m³ ;
 - (ii) a total developed surface area of 7.70 m².
- E.4(d)** No point of any foil shall exceed 5750 mm either side of the hull centreplane when the two foils are retracted symmetrically.
- E.4(e)** When the foil is extended to its maximum static moment, the Y value of the centroid of each foil section shall not decrease from the hull centreplane to the tip of the foil.
It is specifically permitted for the centroid values of the foil's end sections to decrease from a single series of normal foil sections within a maximum Y limit of 105 mm and a maximum Z limit of 210 mm, whatever the second degree of freedom if it exists.
- E.4(f)** It is expressly permitted to attach one or several fixed fences on each foil to prevent localised ventilation from occurring.
This type of fence shall be :
- (i) non-adjustable in relation to the foil ;
 - (ii) be attached to the perpendicular of the foil ;
 - (iii) of a width of less than 50 mm on each side of the foil blade.
- E.4(g)** A foil shall pass just once through the **hull** shell. The intersection of the foil and **hull** shell shall be above the boat reference XY plane.

- E.4(h)** A foil shall be able to retract into and extend out of the **hull** shell and shall use only one degree of liberty for this movement. The section of foil which retracts into and extends out of the **hull** shell shall have constant normal sections.
- E.4(i)** It is expressly permitted for a foil to have a second degree of freedom. If it exists, the degree of freedom shall be a rotation of the foil which shall be limited to an angle of 5.0 degrees.
- E.4(j)** No mechanism shall be used to induce distortion of the foil. Only distortion generated by hydrodynamic forces and those generated naturally by the systems associated with the movement(s) of the foil described in CR E.4 are expressly permitted.
- E.4(k)** Impact : In the event that a foil suffers a significant impact, it must be demonstrated to the CM that its installation enables the watertight compartment around the foil casing to remain intact.
- E.4(l)** The characteristics of the foil shall be validated by the CM prior to installation on the **boat**.
- E.4(m)** In general, the measurement protocol details how to check the conformity of the foils' characteristics and their installation on the **boat** to verify that the whole set-up complies with all the CR.

E.5 RUDDER

- E.5(a)** The number of rudders shall be 2.
- E.5(b)** The “fully down” position of a rudder shall be its normal use position.
- E.5(c)** The rudder in its “fully down” position shall be included in the hull length.
- E.5(d)** In any other cases where the rudder is stable or fixed in position other than the “fully down” position, the CM shall be satisfied that the rudder has no effect on the flow of water on and near the **hull** shell.
- E.5(e)** The rudder's attachment points on the **hull** shall be permanently installed and remain in place.
- E.5(f)** All points along the leading and trailing edge of the rudder shall be on the same plane.
- E.5(g)** Below the **hull** shell, a fence may be fitted on each rudder to prevent localised ventilation. This fence shall be :
- (i) non-adjustable in relation to the rudder ;
 - (ii) perpendicular to the axis of rotation of the rudder in the transverse plane ;
 - (iii) attached no more than 200 mm below the **hull** shell when the rudder is in its “fully down” position ;
 - (iv) of a width of less than 30 mm on each side of the rudder blade.
- E.5(h)** In measurement trim, the dihedral angle between the plane defined in E.5(f) of each rudder and the plane XZ shall be less than or equal to 30°.

SECTION F RIG

F.1 STANDARDISED MAST

- F.1(a)** The **boat** shall be equipped with a standardised mast which shall :
- (i) comply with CR APPENDIX C ;
 - (ii) hold a certificate of conformity from IMOCA ;
 - (iii) be weighed in a configuration defined by the CM, with corrector weights added if necessary ;
 - (iv) be the 2nd generation standardised mast.
- F.1(b)** To use the standardised mast safely, the skipper shall follow the manual for stepping and use of the standardised mast as described in Note 2 or Note 5 provided by the builder upon delivery.
- F.1(c)** The standardised mast shall not be **modified** (structural or cosmetic **modifications**) except for modifications that can be defined as “running rigging and fittings which are not essential to the function of the mast as elements of the rig”, and **modifications** permitted in CR APPENDIX C.
- F.1(d)** Any **repairs** shall be made with the CM’s prior approval and under his supervision.

F.2 AIR DRAUGHT AND MAST

- F.2(a)** The air draught shall not exceed 29000 mm in measurement trim.
- F.2(b)** Whilst racing, the mast rake shall not be adjustable. It is measured from the boat reference and it shall be between 2.0 and 6.0 degrees.
- F.2(c)** A laterally canting mast is expressly forbidden and the mast shall never be canted to windward of the centreline of the boat.
- F.2(d)** The shrouds and stays must never be disconnected or adjusted when at sea.

F.3 STANDING RIGGING

- F.3(a)** The standing rigging shall comply with CR APPENDIX C.
- F.3(b)** Forestay 2 shall not be removable nor adjustable *when racing*.

F.4 OUTRIGGERS

RRS rule 55.3 is changed as follows :

- « **F.4(a)** The outriggers supplied with the standardised mast shall be used solely for holding up the rig and for sail trim.
- F.4(b)** Other outriggers may be used solely to assist with sail trim either to *leeward*, or to *windward*. These outriggers may be partially stowed aft of point X=0 of the boat reference. »

F.5 STANDARDISED BOOM

- F.5(a)** The **boat** shall be equipped with a standardised boom which shall :
- (i) Comply with CR APPENDIX M ;
 - (ii) hold a certificate of conformity from IMOCA ;
 - (iii) be weighed in a configuration defined by the CM, with corrector weights added if necessary.
- F.5(b)** To use the standardised boom safely, the skipper shall follow the manual for installation and use of the standardised boom as described in Note 3 provided by the builder upon delivery.
- F.5(c)** The standardised boom shall not be **modified** (structural or cosmetic **modifications**) except for modifications that can be defined as “running rigging and fittings which are not essential to the boom as elements of the rig”, and **modifications** permitted in CR APPENDIX M.
- F.5(d)** Any **repairs** shall be made with the CM’s prior approval and under his supervision.

SECTION G SAILS

G.1 GENERAL REMARKS

- G.1(a)** The maximum number of sails allowed on board *when racing* is 7.
- G.1(b)** A sail shall never be positioned :
- (i) above the highest point of the mast ;
 - (ii) forward of the forwardmost point used to determine LOA ;
 - (iii) aft of the aftermost point used to determine LOA (see CR D.2(a) et D.2(b)).

G.2 LIMITATIONS

- G.2(a)** The number of active sails associated with the **boat** is defined in CR APPENDIX N.
- G.2(b)** Inflatable systems (battens, luff, etc.) are expressly forbidden for sails.

G.3 HEADSAILS

- G.3(a)** A storm jib, with a surface area between 14 and 25 m², made of heavyweight and of highly-visible colour shall be on board and shall be capable of being safely set in heavy weather conditions.
- G.3(b)** *When racing*, the J2 shall be permanently attached to forestay 2.
- G.3(c)** In the case of repairing the J2, the sail may be lowered from the deck.
- G.3(d)** Specifications :
- (i) Headsails shall be furled when they are not in use, except for spinnaker-type sails (where the half width is equal or greater than 75% of the foot length).
 - (ii) Headsails where the width at mid-height is equal to or greater than 60% of the foot length shall have no battens.

G.4 IDENTIFICATION

All *sails* carried on board *when racing* shall be identified as specified marked by the CM as described in CR APPENDIX N.

G.5 SAIL MATERIAL

Carbon fibre is expressly forbidden in sails.

SECTION H ELECTRONIC EQUIPMENT

Any sensor at a manufacturer's cost price greater than € 10,000 ex-tax, shall be *commercially produced* and featured on a list approved by the CM.

This list is defined in CR APPENDIX P.

CHAPTER III APPENDICES TO THE CLASS RULES

APPENDIX A GRANDFATHER RULES

The rules in CHAPTER I and CHAPTER II relating to standardised equipment apply to *IMOCA* fitted with this equipment.

A **boat** which has been issued with a MC before 1st January 2013 may apply the grandfather rules described in the CR.

Non-compliance with a current rule of the CR is permitted only when a grandfather rule specifically permits it.

For a grandfather rule to be applicable, it depends on :

- the date of the first MC ;
- or the date of the new **boat** building declaration ;
- or the date of the measurement of the equipment in question.

he list of applicable grandfather rules according to the criteria described in CR **Erreur ! Source du renvoi introuvable.**

AA.1 GENERAL REMARKS

AA.1.1 A **boat** benefitting from a grandfather rule shall not make **modification(s)** that go against the intention of any new rules.

AA.1.2 One or several CR may, in particular, not apply : D.2(a) & D.2(b) & D.2(c) & D.2(d) & D.2(e) & D.2(f) & D.6(b) ; E.4(b) & E.4(c) & E.4(d) & E.4(e) & E.4(k) ; E.5(c) ; SECTION H ; AB-1.3 (Grounding/ impact criteria).

AA.2 HULL

AA.2.1 A **boat** which has been issued with a MC and undergoes modification to its **hull** shell shape, including below the **sheerline** (topsides + underside), over a surface area of 50% or more, must meet all the CR pertaining to a new **boat**.

The date of the first MC issued for the **boat** in question defines its initial **hull** shell shape.

It cannot cumulatively over time undergo modifications greater than the value specified in the current rule, which is less than 50%.

- AA.2.2** A **boat** whose **hull** is modified cannot increase its maximum beam over the value it had prior to modification, at the issue of its last MC, unless the maximum beam of the **hull** was less than 5.85 m.
- AA.2.3** Where modifications are made to the **hull**, a **boat** shall comply with CR D.3. If it is impossible to comply with this rule, and before any modification to the **hull**, permission must be granted by the CM to use the materials specific to its **hull**.
- AA.2.4** CR D.2(f) does not apply to a **boat** covered by a grandfather rule.
- AA.2.5** Where existing **hull** shell and deck moulds which have been used to build an *IMOCA* are re-used, it is expressly permitted to not apply CR D.2(f) on the express condition of maintaining the height of the **sheerline** in the existing moulds and that no modification will result in a lowering of these values.

AA.3 STRUCTURE AND NDT OF THE BOAT

- AA.3.1** Where a **boat's** MC is more than 4 years older than the date of the request for a new MC, the *skipper* or their designated representative shall provide an NDT of the **boat** dated close to the date of the request for a new MC.

This NDT shall be :

- carried out by a recognised qualified surveyor, in good faith and using appropriate methods ;
- submitted to the CM.

The CM will reject a full **boat** inspection report if he deems it to be incomplete or carried out by someone whose level of expertise is considered insufficient.

The Executive Committee of *IMOCA* can, at its sole discretion and without explanation, ask the CM to not issue a MC.

- AA.3.2** The **hull** of a *boat* (excluding associated fittings and any corrector weights) may be built without complying with all of the requirements of CR APPENDIX G.
- AA.3.3** The parts of CR AG.1 relating to T800S fibre and the nominal weight of each *cloth*, does not apply.
- AA.3.4** CR AG.2(c) & AG.2(d) & AG.2(e) do not apply.
- AA.3.5** CR AG.2(e) does not apply.
- AA.3.6** Where existing **hull** shell and deck moulds which have been used to build an *IMOCA* are re-used, it is expressly permitted to use *cloth* weighing at least 150 g/m² within the limit of 5% of **hull** weight.

AA.4 STABILITY

The AVSwc value shall be greater than 108 degrees, for **boats** built before 2010 and which have retained a carbon *keel* and/or a configuration with more than four ballasts.

AA.5 KEEL

It is expressly permitted that the theoretical static efforts and the loads listed in CR AB-1.3 not be complied with.

AA.6 MAST AND RIGGING

It is expressly permitted that forestay 2, forestay 3, forestay 3 (without a sail), the running backstays and the deflectors listed in CR **Erreur ! Source du renvoi introuvable.** and ordered before 15th April 2021 not be the ones supplied with the standardised mast.

It is expressly permitted that the minimum angles of forestays to comply with AC.3.2(c) be measured for 3° of rake for **boats** issued with a first measurement certificate in 2020.

AA.7 BOOM

AA.7.2 The gooseneck shall be on the deck or have an easily removable pin in the case of dismasting.

AA.7.3 Where this is not the case, a 6000 mm long tube (2 * 3000 mm “sleevable” sections) shall be on board and capable of being used to make a jury rig.

AA.7.4 CR D.1(a)(iv) and **Erreur ! Source du renvoi introuvable.** may not apply.

AA.8 PULPITS AND LIFELINES

AA.8.2 The pulpit may be in 2 parts and open provided that the opening between the pulpit and any part of the **boat** (a fixed, non-removable forestay is a part of the **boat**, removable forestays are not taken into account for this part of the rule) does not exceed 360mm.

AA.8.3 The 2 parts of the pulpit shall not be bridged with a covered SK lifeline when the pulpit is in 2 parts and open, and the opening between the pulpit and any part of the **boat** exceeds 360 mm.

AA.8.4 There may be one break of 500 mm maximum in the continuity of the lifelines on each side of the **boat**, measured along the lifeline, on condition that there is an overlap of at least the same length as the opening.

AA.9 FOIL

It is expressly forbidden to replace a foil which does not comply with CR E.4 with a new identically-built foil.

AA.10 FOIL MEASURED FOR THE FIRST TIME BEFORE 15TH OCTOBER 2020

AA.10.2 CR E.4(b) & E.4(c) & E.4(d) & E.4(e) do not apply.

AA.10.3 In order to use a foil which does not comply with CR E.4(c), the **boat** at rest, at zero heel, in measurement trim shall have a mast rake between 2.0 and 4.0 degrees and the second degree of freedom of the foil shall be limited to 3.0 degrees.

AA.10.4 To be expressly permitted, the foil, its geometry, installation in the **boat** and the associated systems shall not be modified. The foil shape, installation and associated systems shall remain identical except for the aim of complying with CR E.4(c)(i).

AA.10.5 IMOCA equipped with these foils are not obliged to comply with CR APPENDIX O.

AA.11 FOIL MEASURED FOR THE FIRST TIME BEFORE 15TH OCTOBER 2021

CR E.4(d) and AG.2(e) do not apply.

AA.12 ELECTRONIC EQUIPMENT

It is expressly permitted to not comply with CR SECTION H for any electronic equipment installed on board prior to 15th April 2021.

AA.13 GRANDFATHER RULES WHICH APPLY FOR A BOAT WITH A FIRST MC

AA.13.2 Obtained between 1st May 2013 and 1st May 2015

AA.1, AA.2, AA.3.1, AA.3.3, AA.3.4, AA.3.5, AA.5, AA.6, AA.7, AA.8, AA.9, AA.10, AA.11, AA.12.

AA.13.3 Obtained between 1st January 2015 and 15th October 2020

AA.1, AA.2, AA.3.1, AA.3.3, AA.3.4, AA.3.5, AA.5, AA.6, AA.7.3, AA.9, AA.10, AA.11, AA.12.

AA.13.4 In connection with a new build declaration between 1st January and 15th October 2020

AA.1, AA.2, AA.3.1, AA.3.3, AA.3.4, AA.3.5, AA.3.6, AA.5, AA.6, AA.7.3, AA.9, AA.10, AA.11, AA.12.

AA.13.5 Obtained between 15th October 2020 and 15th October 2021

AA.1, AA.2, AA.3.1, AA.3.6, AA.5, AA.6, AA.7.3, AA.9, AA.12.

AA.14 ENERGY / ENGINE

AA.14.1 Boats that received their first MC before the 2016 Vendée Globe may keep the following commercially produced 35hp engines : Yanmar 3JH5E, Lombardini LDW 1404, Nanni diesel N4.38, Volvo D2-40 meeting the 280 daN traction criterion.

AA.14.2 Boats that received their first MC between 1st January 2017 and 1st January 2025 may keep the following commercially produced 35hp engines : Yanmar 3JH5E, Lombardini LDW 1404, Nanni diesel N4.38, Volvo D2-40 by meeting the 280 daN traction criterion; they will be fitted with 50 kg weight within 500 mm of the engine from 1st January 2025.

AA.14.3 Boats that have received their first MC before 1st January 2025 may not comply with the minimum distance from the propeller to the transom of 1500 mm specified in CR C.6.1(e).

AA.15 SAILS

For **boats** not fitted with a standardised mast, CR G.1(a) is replaced by this rule :

« The maximum number of sails allowed on board *when racing* is 8. »

AA.16 STANDARDISED MAST

For **boats** that received their first MC before 1 January 2026, CR F.1(a)(iv) is replaced by the following rule :

« be the 1st generation standardised mast or be the 2nd generation standardised mast. »

AA.17 HYDRAULIC SYSTEMS

For **boats** not equipped with a standardised boom, CR C.11 is replaced by the following rule :

« No hydraulic system shall be on board a boat, with the exception of :

- the keel canting system ;
- the second degree of freedom adjustment for the foils ;
- the trim of headsails tack points, the cunningham and the mainsail outhaul ;
- rudder trim to affect yaw. »

APPENDIX A-1 DESIGN OF A NON-STANDARDISED KEEL FIN

The keel fin shall be a single block, and shall not have any welds, nor bonding for its structural parts.

AA-1.1 MATERIALS FOR THE KEEL FIN

Forged steel with the minimum following properties :

- Minimum resilience = 85 J ;
- Elastic limit (RP) at 0.2% : 800 MPa minimum ;
- Minimum elongation : 12%.

The following materials are accepted :

- VG900i from « Thyssen » ;
- APX4 from « Aubert et Duval » ;
- and any material which has been given prior written approval by the CM.

AA-1.2 GEOMETRICAL CONSTRAINTS

Cavities are permitted under the following conditions :

- The minimum width of a cavity is 30 mm ;
- The maximum depth of a cavity in mm is equal to : $(2 * \text{the width of the cavity in mm}) + (90 \text{ mm})$;
- Cavities shall be filled with material whose density is less than 7800 kg/m^3 ;
- No structural cover shall be used to seal a cavity ;
- The maximum depth of a cavity shall not exceed 210 mm (for a width of 60 mm or more) ;
- It shall be possible to remove the non-structural hydrodynamic elements and fairings for inspection purposes.

AA-1.3 DIMENSIONING

The XYZ reference is that of the **boat**.

The attachment zones correspond to the load zones, and are 3 in number :

- keel head pin zone ;
- keel rotation axis zone ;
- bulb to keel fin attachment zone.

The keel head insert into the **hull** shall be 450 mm minimum.

AA-1.3.1 CASE 1

Keel horizontal, 1g on the keel, reaction at the keel head, locked off, with the angles and the degrees of freedom relevant to the ram.

- Coefficient of 5 for Rp 0,2 minimum for the whole keel ;
- Coefficient of 6.5 for Rp 0,2 minimum in the attachment areas.

AA-1.3.2 CASE 2

Grounding/impact : keel vertical : apply 27 tonnes to the forward tip of the bulb on the X axis.

- Coefficient of 1 minimum for the breaking strain of the material.
- Check that the elastic limit of the keel bearings and the parts for attaching the keel is not exceeded.

AA-1.3.3 COMBINED LATERAL + LONGITUDINAL CASE

Keel horizontal, reaction at the keel head, locked off, with the angles and the degrees of freedom relevant to the ram/or the back-up ram (choose the least favourable case).

The following shall be applied : $(\text{Gravity Z} * 2,5 + \text{Gravity X}) * 2$; gravity X shall be applied towards the bow of the boat and then towards the stern of the boat.

- Coefficient of 1 minimum for Rp0.2.

NOTE : The required criteria is a globally plastic behaviour, meaning an absence of residual deformation (residual deflection of the keel fin) after loading. Exceeding the elastic limit in localised areas (a fillet, for example) is acceptable.

AA-1.4 NATURAL KEEL FREQUENCIES

With the keel fitted to the **boat**, rotation axis in place, the hydraulic system attached and locked off in the middle, the natural frequency of the keel shall be equal to or greater than :

- A - 3,4 Hz in torsion (Rot Z) ;
- B - 1,1 Hz in lateral bend (Rot X) ;
- C - 4 Hz in longitudinal bend (Rot Y).

Ratio of A/B >2.7.

AA-1.5 CALCULATION METHOD

FEA (finite element analysis) calculation with solid volumic elements – linear domain with justification required :

- Recommended Tetra 6 grid : 10 mm globally down to 2 mm locally in fillets and attachment points ;
- Locking : “bearing” type for the rotation axes and keel head pin ;
- Aft bearing locked in Fx + Fy + Fz ;
- Forward bearing locked in Fy + Fz ;
- Keel head axis locked in order to match the hydrau ram angular load reaction components.

AA-1.6 DOCUMENTS TO BE SUPPLIED TO THE CM

- Grid view ;
- Lateral Deflection @ 1.G keel horizontal ;
- Modal deflections and natural frequencies ;
- Overview : Von Mises ;
- Overview : Principal stresses ;
- Local view for high load zones and attachment points ;
- XZ plan view @ Centreline : Von Mises ;
- “Horizontal” view at the bearings ;
- “Horizontal” view at the keel head ;
- “Horizontal” view at the base of the keel ;
- “Horizontal” view at the mid-height level of the keel ;
- “Horizontal” view at 200 mm above the bearings.

AA-1.7 MODIFICATION

No modifications shall be made to the keel or part of the keel without a new full structural analysis and submission of modifications to the CM.

APPENDIX B STANDARDISED KEEL FIN AND CANTING SYSTEM**APPENDIX B-1 STANDARDISED KEEL FIN**

The standardised keel fin is supplied by AMPM.

AB-1.1 ASSOCIATED DRAWINGS AND DOCUMENTS

The drawings and documents associated with CR APPENDIX B-1 shall be consulted along with the latest update and/or the latest current version.

These are available on the website in the IMOCA “member” section at : <https://www.imoca.org/en/technical-committee-documents>

- (i) 0669_IMOCA_HDS_Quille monotype_Principe de montage Axe Verin_20141002
- (ii) 0669-1000 - Quille IMOCA - IND H - Geometrie generale – Annexe B-2013
- (iii) 0669-1310 - Quille IMOCA - IND B - Assemblages Composite
- (iv) 0669-1410 - Quille IMOCA - IND E - Principes assemblages metal – Bulbe
- (v) 0669-1420 - Quille IMOCA - IND D - Assemblages metal - Axe verin
- (vi) Plan de détail palier vérin
- (vii) Plan des entraxes 2/ assemblage verin bras

AB-1.2 DESCRIPTION

Equipment supplied includes :

- the finished standardised keel fin, equipped with its fairings and ready to paint ;
- the ram pin.

Not included :

- the keel rotation bearings ;
- the bushings, locking pins, and the elements required to attach standardised keel fin to the bulb ;
- the bulb ;
- the olive (standardised keel fin fairing through the **hull**) ;
- bolts and/or any other means required to attach the standardised components on board ;
- all components relating to the watertight integrity of the system (baffles, cable glands, etc.).

The standardised keel fin shall be issued with a certificate of conformity from IMOCA, which will give it a number, and it shall be delivered with a conformity report.

The approved supplier shall provide a quality control record, to be signed by the client.

AB-1.3 INSTALLATION

The theoretical static loads and forces which shall be factored in for the specifications and build of the structure around the keel bearings are :

- Grounding/ impact at the base : 6.0G ;
- Impact below the keel head pin : 1000 kN @1.0 m ;
- Keel angle : 3.5G.

	Static load	Safety coefficient	Supplier	Load to be taken into account	Static load (C.S.=1) grounding impact
On the forward keel bearing	27,8 T	6,5	TEAM	180,7 T	144 T
On the aft keel bearing	13,1 T	6,5	TEAM	85,2 T	147 T
On the keel head pin	37,6 T	4	STANDARD	150,4 T	-
On the principal ram bearing	37,6 T	3	STANDARD	112,8 T	-
On the safety ram bearing	31,0 T	3	STANDARD	93 T	-

The skipper or their designated representative shall submit a report on the relevant studies to the CM.

AB-1.4 BULB WEIGHT / INERTIA

The bulb shall conform to the following limits :

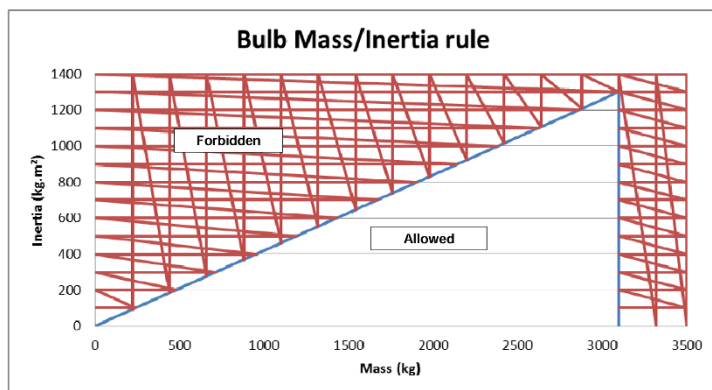
**APPENDIX B-2 STANDARDISED CANTING SYSTEM DESCRIPTION**

The standardised canting system is supplied by Hydroem.

AB-2.1 ASSOCIATED PLANS AND DOCUMENTS

The plans and documents associated with CR APPENDIX B-2, as well as Note 1 (Specifications for the installation and operation of the standardised canting system) shall be consulted along with the latest update and/or the latest current version.

These are available on the website in the IMOCA "member" section at : <https://www.imoca.org/en/technical-committee-documents>.

3D Peripherique Electronique – STEP :

- (i) *ARMOIRE CAPAS V2 AVP0* ;
- (ii) *GESTION QUILLE L2 AVP0* ;

3D Peripherique Hydrauliques – IGS :

- (iii) *5 Vase d'expansion* ;
- (iv) *Groupe electro-hydraulique lynch* ;
- (v) *Manifold* ;
- (vi) *Pompe manuelle* ;

3D Systeme Principal – STEP :

- (vii) *0669 - IMOCA Quille Standard - Assemblage General 0° - 2014-05-15* ;
- (viii) *0669 - IMOCA Quille Standard - Assemblage General 38° Babord - 2014-05-15* ;
- (ix) *0669 - IMOCA Quille Standard - Assemblage General 38° Tribord - 2014-05-15* ;
- (x) *Bras de sécurité* ;
- (xi) *Verin hydraulique* ;

NOMENCLATURES :

- (xii) *Bras de sécurité Nomenclature 3D* ;
- (xiii) *Groupe electro-hydraulique lynch* ;
- (xiv) *Manifold Nomenclature 3D* ;
- (xv) *Vase d'expansion* ;
- (xvi) *Verin hydraulique Nomenclature 3D* ;

(xvii) *Cahier des Charges d'implantation et d'utilisation du système de contrôle standardisé V1.2.*

Note 1 : Specifications for the installation and operation of the standardised canting system.

AB-2.2 DESCRIPTION

Equipment supplied includes :

- the kee head pin ;
- the ram with trunnion ball joint ;
- mechanical locking system ;
- drilled hydraulic manifold block ;
- hydraulic control system ;
- the JPS Concept operating system ;
- 2 capas + 1 charger + 1 container ;
- a summary of the estimated weight of the components.

AB-2.3 COMMISSIONING, OPERATION AND MAINTENANCE

AB-2.3.1 COMMISSIONING

Commissioning the standardised canting system shall be done in the presence of the approved suppliers. Commissioning includes sea trials. A report of the trials shall be provided by the approved supplier and signed by the client.

AB-2.3.2 SUPPLIERS' RECOMMANDATIONS

All the suppliers' recommendations are available in the installation and operation manuals (Note 1) and shall be adhered to for safe and proper use.

The kee must be protected against electrolysis in particular.

AB-2.3.3 INSPECTIONS AND MAINTENANCE

The standardised canting system shall undergo regular maintenance.

Maintenance shall be carried out by the approved supplier or under the supervision of the approved supplier.

Under no circumstances shall the system be opened without prior consultation and authorisation from the approved supplier.

Inspection and/or maintenance records may be required for the issue of a MC.

APPENDIX C STANDARDISED MAST

The standardised mast is supplied by CDK Technologie and LORIMA, and the design work is carried out by Gsea Design. From 1st November 2024, production of 1st generation standardised masts will cease.

AC.1 PLANS AND DOCUMENTS FOR THE 1ST GENERATION MAST

AC.1(a) The plans and documents associated with CR AC.1 as well as Note 2 (Specifications for the stepping and use of the 1st generation standardised mast) shall be consulted along with the latest index (revision) and/or the latest date in force.

The list of documents comprising this set is available in the measurement protocol.

These are available on the website in the IMOCA “member” section at : <https://www.imoca.org/en/technical-committee-documents>.

AC.1(b) Note 2 is supplied by the builder when the mast is delivered.

The skipper shall comply with the provisions in Note 2 for the safe and proper use of the standardised mast.

The drawings in this document are for illustration purposes.

AC.2 PLANS AND DOCUMENTS FOR THE 2ND GENERATION MAST

AC.2(a) The Note 5 (Specifications for the installation and use of the 2nd generation standardised mast) must be considered with the latest index (revision) and/or the latest date in force.

It is available on the IMOCA “member” section platform at : <https://www.imoca.org/en/technical-committee-documents>.

AC.2(b) The plans and documents associated with CR AC.2 shall be consulted along with the latest index (revision) and/or the latest date in force.

The list of documents comprising this set is available in the measurement protocol.

They are available on the TEAMS DOCUMENTS Drive, accessible upon signing the non-disclosure agreement available on the IMOCA member platform (<https://www.imoca.org/en/technical-committee-documents>), to be sent to the technical unit (cellule.technique@imoca.org).

AC.3 MAST STEPPING

The following rules shall apply for stepping the standardised mast on the **boat**.

AC.3.1 FORCES AND LOADING

Note 2 and Note 5 indicate the theoretical static loads and forces corresponding to the 1st and 2nd generation standardised masts respectively.

The standardised mast installation on the **boat** shall factor in this data.

The **hull** structure and all associated items of equipment shall be suited to these loads and have sufficient safety coefficients built in for participation in all « IMOCA Globe Series » Championship races.

AC.3.2 POSITION OF CHAINPLATES AND MAST BASE

- AC.3.2(a)** The 0 reference for the standardised mast, as defined in Note 2 and Note 5, shall be positioned between X = 7700 mm and X = 8700 mm (X = 0 : it is the aftermost point of the hull).
- AC.3.2(b)** The position for the outrigger tie-rods on the **boat** shall be such that the angle between the tie-rod and the outrigger shall be greater than 23.3 degrees on the plane between these two axes.
- AC.3.2(c)** The minimum and/or maximum angles of the forestays and runners shall be complied with for the installation of the standardised mast on the deck.
They are measured for 4.0 degrees of rake and defined in appendix 3 of Note 2 and Note 5.

AC.3.3 RAKE AND ROTATION

- AC.3.3(a)** See F.2(b).
- AC.3.3(b)** The mast rotation shall not exceed +/- 40.0° in relation to the hull centreplane.

AC.4 RIGGING**AC.4(a) Lateral standing rigging**

The 2 cap shrouds (G1) and the 2 lower shrouds (G2) are supplied with the standardised mast.

Textile SK loops to attach G1 and G2 to the mast are supplied with the standardised mast.

Chafe protection may be added on G1 and G2 on condition that it does not change their mechanical properties.

Fairings and other systems designed to improve the aerodynamics or affect sail trim are expressly forbidden.

AC.4(b) Outrigger tie-rods

The 2 outrigger tie-rods are supplied with the standardised mast.

Their lengths are unrestricted, and shall be specified by the client ordering the standardised mast.

Chafe and/or impact protection may be added on the outrigger tie-rods on condition that it does not change their mechanical properties.

Fairings and other systems designed to improve the aerodynamics, hydrodynamics or affect sail trim are expressly forbidden.

AC.4(c) Forestays and backstays

- (i) The rigging of the 1st generation standardised mast must comply with the appendix 3 of the Note 2.

Forestay 2, forestay 3, forestay 3 (without a sail), the running backstays shall be those supplied with the 1st generation standardised mast.

Their lengths are unrestricted, and shall be specified by the client ordering the standardised mast.

Lashings and textile loops for attaching these items of rigging to the mast are not supplied with standardised mast.

Adding chafe and/or impact protection is expressly permitted on condition that it does not change the mechanical properties of the rigging.

Fairings and other systems designed to improve the aerodynamics, hydrodynamics or affect sail trim are expressly forbidden.

It is expressly permitted to add an attachment point for a sail which is not at the end of the cable.

- (ii) The rigging of the 2nd generation standardised mast must comply with the appendix 3 of the Note 5.

Forestay 2, forestay 3, forestay 3 (without a sail), the running backstays and deflector shall be those supplied with the 2nd generation standardised mast.

Their lengths are unrestricted, and shall be specified by the client ordering the standardised mast.

Lashings and textile loops for attaching these items of rigging to the mast are not supplied with standardised mast.

Adding chafe and/or impact protection is expressly permitted on condition that it does not change the mechanical properties of the rigging.

Fairings and other systems designed to improve the aerodynamics, hydrodynamics or affect sail trim are expressly forbidden.

It is expressly permitted to add an attachment point for a sail which is not at the end of the cable.

AC.5 MAST DESCRIPTION

AC.5(a) Tube

Reference axes :

- **X** → horizontal ;
- **Y** → transverse ;
- **Z** → vertical.

0 de référence (0 mast = 0 lay up) :

The origin of the mast reference on the longitudinal axis of the mast is the intersection :

- of the projection of the aft face of the carbon tube on the centreplane of the hull with a nominal rake angle of 3.0° ;
- with the mast step in the mast plane = 3.0°.

This point provides the longitudinal position of the mast (which is : 8200 +/- 500mm) in the boat reference (see drawing below).

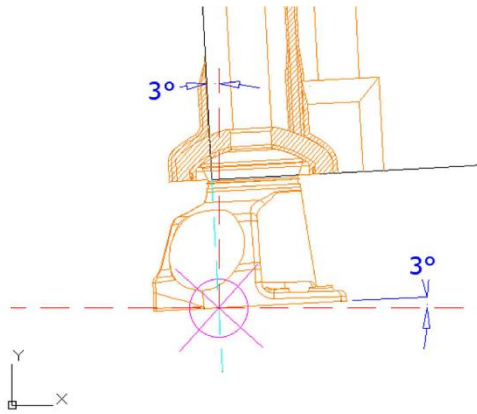
**AC.5(b) Tube geometry**

Defined in CR AC.1(a) or CR AC.2(b).

AC.5(c) Weight and CG of the mast tube

The weight of the 1st generation mast tube with its fittings shall be 310 kg. If the CM adds corrector weights, these shall be sealed in the position defined in the measurement protocol.

The weight of the 2nd generation mast tube with its fittings shall be a maximum of 320 kg. If the CM adds corrective weights, these must be sealed at the location defined in the measurement protocol.

AC.5(d) Mast track and mainsail halyard lock

Defined in CR AC.1(a) or CR AC.2(b).

AC.5(e) Mainsail head altitudes

Defined in CR AC.1(a) or CR AC.2(b).

AC.5(f) Mast base

The mast is stepped onto a ball.

The mast base is supplied with the mast.

AC.5(g) Rotation arm

A single attachment point on the forward face of the tube.

The section is stiffened with an omega to prevent it from buckling.

AC.5(h) Gooseneck

Defined in CR AC.1(a) or CR AC.2(b).

The loads and conditions for use are described in Note 2 or Note 5.

AC.5(i) Cunningham

At the gooseneck level in the reinforced section on the starboard side, a toggle may be used for the fixed point of the cunningham.

AC.5(j) Boom vang

No boom vang or equivalent system designed to adjust the leech tension of the mainsail shall be attached to the mast and/or the mast base.

AC.5(k) Radar

1 reinforcement with a hole for the cable and/or support bracket attachment is situated on the front face of the mast.

The centre of the radar cable hole shall be at a Z height between 3462 and 3676 mm for the 1st generation standardised mast.

The centre of the radar cable hole shall be at a Z height of 3675 mm for the 2nd generation standardised mast.

The radar support bracket shall be bonded to the mast and is not supplied with the mast.

Deck lights may be installed on the radar support bracket.

AC.5(l) Lazy-jacks

Lazy jacks shall be attached to the attachment points of the lower shrouds or to the lashings or textile loops of the lower shrouds.

AC.5(m) Height of shroud attachment points

Defined in CR AC.1(a) or CR AC.2(b).

AC.5(n) Forestay attachment points

The attachment points are toggles designed for attaching a halyard lock with a lashing or a textile loop.

The halyard exits are situated below the forestay attachment points.

The heights are defined in CR AC.1(a) or CR AC.2(b).

(The J0 attachment point is calculated to be used for the J1 if necessary.)

AC.5(o) Running backstays

The heights are defined in CR AC.1(a) or CR AC.2(b).

The deflector is fitted with a halyard lock which has only 2 positions (ON/OFF).

The deflector shall be pre-tensioned to 0.2 to 0.3 tonnes in the OFF mode.

AC.5(p) Masthead

The masthead is a U-shaped laminated carbon box.

Mainsail halyard : a fixed point can be used for the halyard termination.

Masthead units, antennas and navigation lights are not supplied with the standardised mast. Their installation and associated mounts are not limited by the current rules.

AC.5(q) Protection

Protective patches may be placed on the mast. It must be proven that these patches are non-structural and are solely for the purpose of protecting the mast.

Under the radar, soft padeyes may be bonded to the mast to attach deflector lines or stow unused halyards.

The equipment required for a mast rotation angle sensor may be mounted on the mast base.

The mast shall be painted and may be decorated with advertising vinyls and comply with CR **Erreur ! Source du renvoi introuvable.**

AC.5(r) Outriggers

Outrigger length : 6250 mm.

Outriggers shall be attached to the mast base supplied with the standardised mast.

Outriggers may be used for foresail trim, and in that case, the criteria below shall be respected.

Outrigger use criteria : see Note 2 or Note 5.

AC.5(s) The use of fibre optics is expressly permitted. Any system chosen by the skipper shall be authorised by the CM who must have access to the data measured.

AC.6 DELIVERY

AC.6(a) IMOCA issues a number for each standardised mast which shall display an identification mark.

AC.6(b) The entire standardised package shall be delivered with :

- (i) a certificate of conformity ;
- (ii) Note 2 or Note 5 ;
- (iii) the standardised study defined by IMOCA.

AC.6(c) The quality control record is provided by the approved supplier and signed by the client.

APPENDIX D OFFSHORE SPECIAL REGULATIONS

Only the OSR specified in the CR apply.

APPENDIX E BRANDING GUIDELINES

The branding layout for the mainsail, the skipper's, crew's and technical team's clothes as well as the description of the in-port promotional sail shall comply with the following requirements :

AE.1 MAINSAIL BRANDING

AE.1(a) Minimum dimensions and position of branding

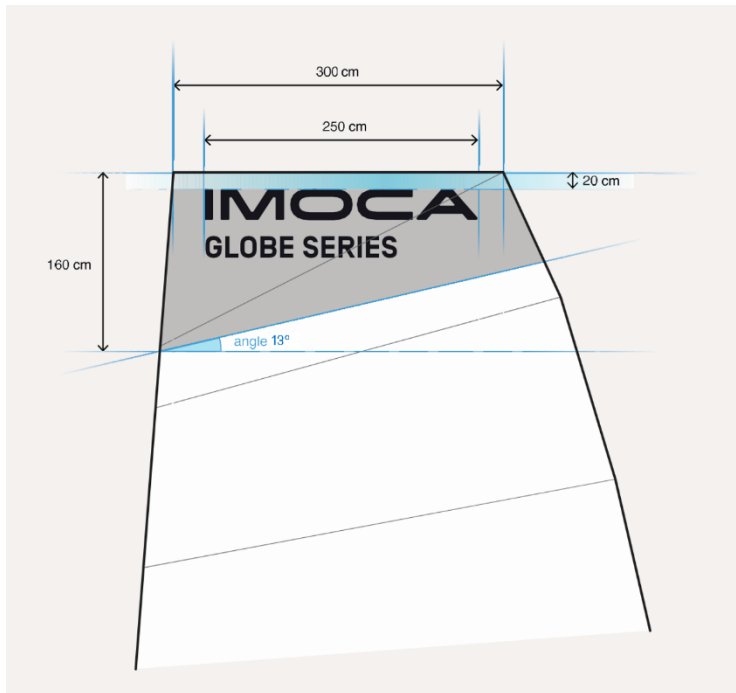

A vector file of the logo can be requested via contact@imoca.org.

If the head of the mainsail is wider than 300 cm, the logo shall be enlarged homogenously.

AE.1(b) Port and starboard layout



AE.2 BRANDING ON THE CLOTHES OF THE SKIPPER, CREW AND TECHNICAL TEAM

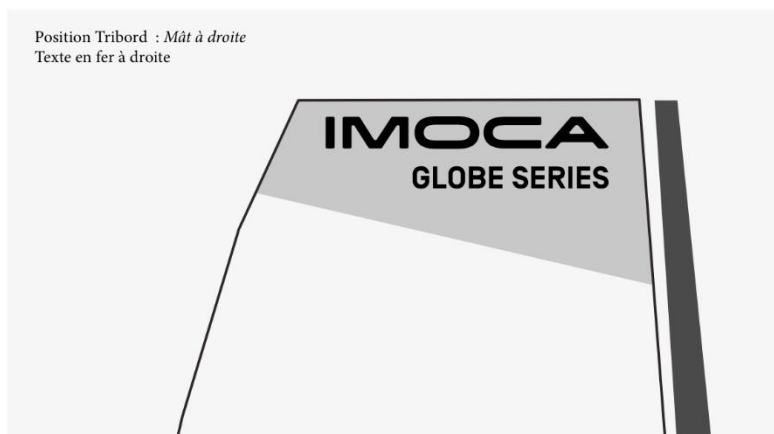

AE.1(c) Specifications for the mainsail logo colours

IMOCA logotype :

- Colour logotype + white lettering + no boundary line with the rest of the mainsail + mandatory contrasting colour between the IMOCA logotype and the rest of the mainsail.
- Colour logotype + colour lettering + no boundary line with the rest of the mainsail + mandatory contrasting colour between the IMOCA logotype and the rest of the mainsail.

The planned artwork shall be submitted without fail by email to [IMOCA](mailto:IMOCA@contact@imoca.org) at contact@imoca.org for approval prior to application.

AE.2 BRANDING ON THE CLOTHES OF THE SKIPPER, CREW AND TECHNICAL TEAM

The *skipper*, crew and technical team shall have visible “IMOCA GLOBE SERIES” branding on their clothes, as described in CR AE.2(b) & AE.2(d).

AE.2(a) Specifications for the logo colours

White or light coloured clothing + IMOCA GLOBE SERIES colour logo

Coloured clothing + IMOCA GLOBE SERIES colour logo

Dark coloured clothing + IMOCA GLOBE SERIES white or light colour logo

AE.2(b) Black or white logotype version



A vector file of the logo can be requested via contact@imoca.org.

AE.2(c) Recommended dimensions

For women and S size clothes : 7.5 cm wide.

For men and clothes M size and above: 8.5 cm wide.

AE.2(d) For white or light coloured clothes



Using the black monochrome version or the options listed in IMOCA's branding guidelines is recommended, and these can be consulted here : <https://www.imoca.org/en/imoca/official-documents>.

AE.2(e) For red, dark blue or dark coloured clothes



Using the white monochrome version or the options listed in IMOCA's branding guidelines is recommended, and these can be consulted here : <https://www.imoca.org/en/imoca/official-documents>.

AE.3 IN-PORT PROMOTIONAL SAIL

From the next solo round the world race, the in-port promotional sail shall be the uniformized in-port promotional sail and shall respect the following requirements :

AE.3(a) Dimensions

- 12 meters high ;
- 2.5 meters wide at the top ;
- 5 mètres de largeur en bas.

It is recommended to hook the in-port promotional sail on reef 3.

AE.3(b) Branding

IMOCA GLOBE SERIES logo on the top of the in-port promotional sail shall respect AE.1(a).

Location, dimensions of the following elements shall respect the following plan :

- portrait ;
- skipper's name ;
- team's name ;
- nationality flag.

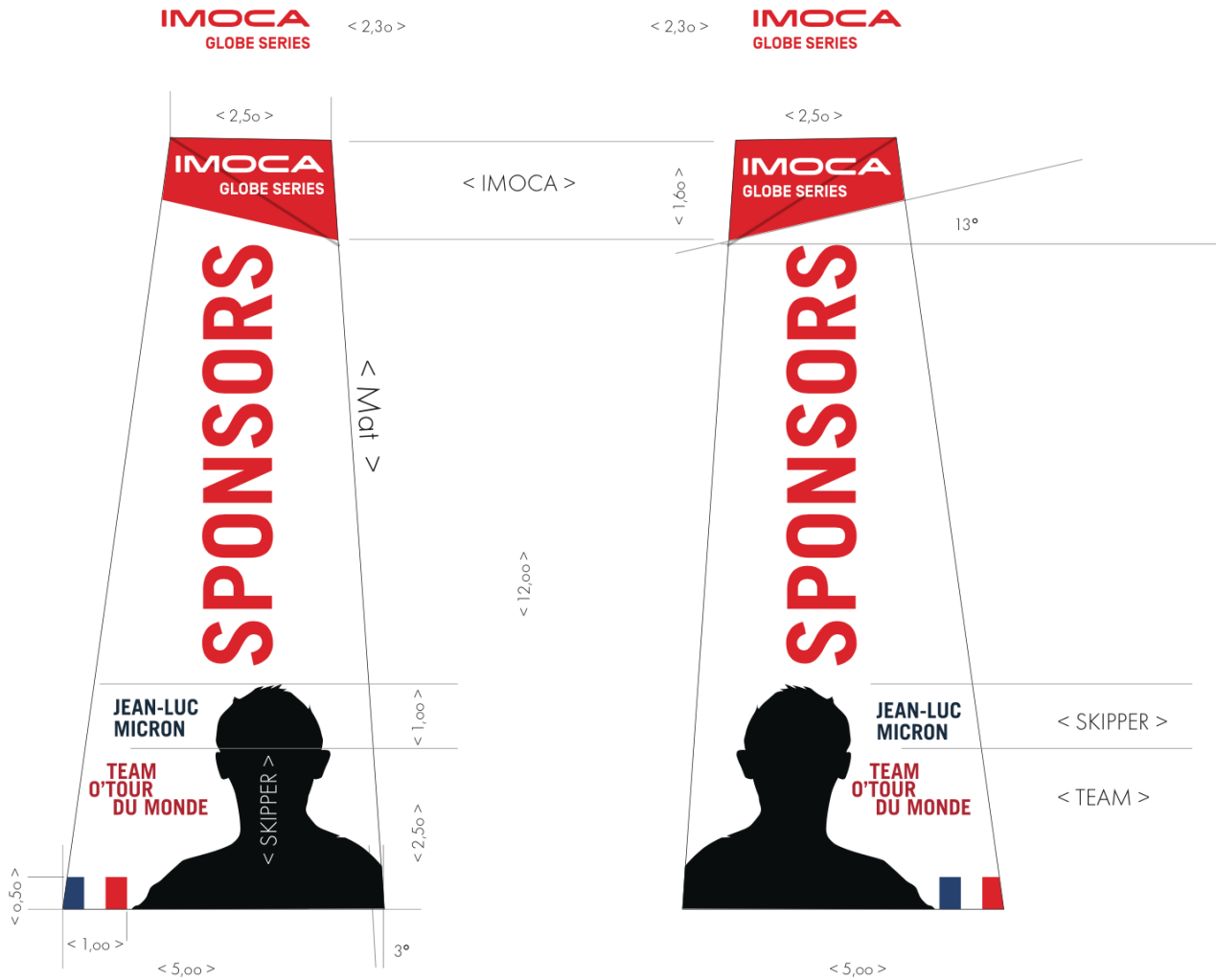

The nationality flag is a choice of the skipper or the team.

Colours, fonts, and general decoration are free and at choice in order to respect the visual identity of the project.

The choice of colour or black and white for the skipper's portrait is free.

The decoration project shall be submitted to IMOCA for validation by email at contact@imoca.org before its realisation.

APPENDIX F CRC / MEASURERS

Composition of the CRC

- Daniel Andrieu : Naval architect
- Jaime Navarro : World Sailing
- Philippe Pallu de la Barrière : C.R.A.I.N.

List of official IMOCA measurers

- Generic adresse : measurers@imoca.org
- IMOCA Chief Measurer : René BOULAIRE : chief.measurer@imoca.org
- Official IMOCA Measurer : Manu GUEDON : manu.guedon@imoca.org
- Official IMOCA Measurer : Thomas JULLIEN : thomas.jullien@imoca.org

APPENDIX G MATERIAL LIMITATIONS, CONSTRUCTION METHODS AND FINISHING PRODUCTS

AG.0 DEFINITIONS

Alternative material: Material manufactured using natural fibres (organic or mineral), and/or **recycled material** designed to be used alone or mixed with bio-based thermosetting matrices >30% or thermoplastic matrices.

Recycled material: material where at least 80% of the mass of the raw material is derived from recycling and/or reprocessing of materials from finished products.

AG.1 MATERIALS

The **boat** without **sail(s)**, in **measurement trim** (without electrical or electronic equipment and associated equipment) shall be built using the following materials which shall be **commercially produced**, except where permitted or forbidden by the CR or the CM :

- aluminium ;
- steel, stainless steel ;
- titanium ;
- bronze, lead ;
- epoxy, polyester and vinylester resin ;
- glass fibre, aramid fibre and carbon fibre ;
- phenolic resin coated paper honeycomb (Nomex®), PVC or SAN foam ;
- wood ;
- moulded plastic, thermoplastic ;
- paint and other chemical products which comply with **Erreur ! Source du renvoi introuvable.**

The rigging (running and standing) shall be of :

- carbone ;
- aramid ;
- vectran ;
- SK ;
- polyethylene ;
- polyester ;
- PBO.

All composite components of the boat – including the **hull** (excluding associated fittings), the **foils**, the rudders, the boom and spars – except the **sails**, shall comply with the following specifications :

- The fibres listed below are permitted :
 - o Hexcel® : IM 7 (6k), IM2A, IM2C, AS7 ;
 - o Hyosung® : H2550 ;
 - o Mitsubishi Chemical Carbon Fiber and Composites® : MR40, MR60H ;
 - o Pyrofil® : TR 50S ;
 - o Tairyfil® : TC 880 ;
 - o Tenax® : IMS 60, IMS 65 ; STS40 F13 24K 1600 tex ;
 - o Toray® : T800H, M30S, T700S, T800SC, T800S ;

- Torayca® : T800SC, T800S ;
- Tornel® : T650/42.

Any other fibre which shall have a tensile modulus of less than 280 GPa, on condition that the CM has approved it.

- HM fibres are expressly forbidden except for the boom, the spars and the foils, which may use M40J, M46J, HS40, HM54 or HM63 (Industrial) fibres.
- Phenolic resin coated paper honeycomb type materials (Nomex®) and foam (PVC and SAN) or alternative materials are the only core materials permitted..
- Para-aramid (N636 or equivalent) or metallic cores are expressly forbidden.
- Core materials shall be commercially produced.
- The nominal weight of each film of glue or the total weight of all films of glue used to bond the phenolic resin coated paper honeycomb type core (Nomex®) or foam core (PVC and SAN) or alternative material core, shall be at least 300 g/m².
- Nanosciences, nanotechnologies and other associated sciences and technologies are expressly forbidden in any resin system for any part of the **boat** except the **sails**.
- The nominal weight of each cloth composed of dry fibres or each composite part manufactured with strips of filament shall be equal to or greater than 200g/m², except a possible exception made for alternative material.

AG.2 CONSTRUCTION METHODS

AG.2(a) The **hull**, excluding associated fittings, the foils and the rudders shall not be heated to temperatures above 135° Celsius during the build process or post-curing stages, with the exception of the use of exclusively thermoplastic matrices.

AG.2(b) The **hull** shell, the deck including any superstructure, the cockpit(s), shall not be built using an autoclave oven.

The maximum pressure applied for vacuum resin infusion of the composite shall not exceed 1.1 Bars.

The following are not included in this rule :

- transom ;
- internal structure and associated fittings.

AG.2(c) The **hull** shell zones situated below a horizontal plane at Z to + 200 mm in the boat reference XY plane shall not be built with phenolic resin coated paper “honeycomb” type core material (Nomex®).

AG.2(d) A maximum of 4 product references of phenolic resin coated paper “honeycomb” type core material (Nomex®) and a maximum of 2 product references of “foam” type core material are the only materials expressly permitted for the deck, including the cockpit(s).

Each product reference is associated with just one quality level, one thickness and one material density.

The following are not included in this rule :

- companionway bulkhead ;
- transom ;
- internal structure and associated fittings ;

- protection for the cockpit(s) ;
- **hull-deck** join.

AG.2(e) The foil beams shall be built solely as monolithic structures of carbon and resin in compliance with APPENDIX G. HM fibres shall not be used in a beam built using a method other than “parallel to the chord axis”.

AG.3 FINISHING AND PAINTING

For the **hull** shell and the hull appendages :

- AG.3(a)** All products used for finishing and painting shall be commercially produced.
- AG.3(b)** Plastic films and vinyls may be used for the sole purpose of branding or decorating the **boat**.
- AG.3(c)** The working deck and all areas where a crewmember may need to work while underway shall have a non-skid finish.

AG.4 ENVIRONNEMENTAL IMPACT REDUCTION OF CONSTRUCTIONS

AG.4(a) Principles

In order to obtain validation of the declaration of construction, the skipper or their representative must provide the CM with all the elements required to verify AG.4(a)(i), AG.4(a)(ii), AG.4(a)(iii), AG.4(a)(iv), AG.4(a)(v), AG.4(a)(vi).

- (i) To obtain a first MC from 1st January 2025, the skipper or their representative must use the IMOCA Eco Score tool of the measurement protocol and available on the IMOCA members area. The IMOCA Eco Score tool can be used to simulate Global Warming Potential (kgCO₂e) impact reductions in relation to the results of Life Cycle Assessments carried out between 2021 and 2024, which establish the impact reference. The impact reductions must be made on the tooling, platform and foil components.
- (ii) The eco-score target of an IMOCA construction must be at least 15%.
- (iii) In the case of mutualisation of tooling between two boat constructions, the eco-score target shall be at least of $(15 - 3*(\text{mutualized tooling PRG}/\text{tooling PRG}))\%$.
- (iv) In the case of mutualisation of foil design, the eco-score target is reduced by 2%.
- (v) The eco-score target cannot be less than 10%.
- (vi) In the event of the mutualisation of tooling for three or more boat constructions over the period of application of the 2028 CR, the Eco-Score target shall be at least of $(15 - 3*(\text{mutualized tooling PRG twice}/\text{tooling PRG}) - 5*(\text{mutualized tooling PRG three times}/\text{tooling PRG}))\%$.

AG.4(b) Special cases

- (i) Reuse of tooling built before 2024 :
 The tooling is removed from the global impact reference.
 The construction of the platform and foils must not have an impact more than 2% greater than that of the first boat built using this tooling.
 The tooling may be modified within a limit of 15% of its surface area.
- (ii) Reuse of tooling built with CR 2028 and modification of less than 15% of the global area of the tooling of the watertight envelope :
 Toolings scores are reallocated to the boat reusing it.
 The construction of the platform and foils shall not have a lower score than the first boat built with this tooling.
 The eco-score target corresponds to the target of the first boat built with this tooling.
- (iii) Reuse and modification of more than 15% of the surface area of the tooling of the watertight envelope built with CR 2028 :
 The score of the reused tooling is reallocated to the boat reusing it.
 The Score of the modification beyond 15% of the tooling area modified is added to the global eco-score calculation.
 The reduction target is determined by the table in the measurement protocol.
- (iv) Any other special case of re-use will be dealt with at the discretion of the CM.

AG.4(c) Penalties

The penalties below shall be cumulative :

- (i) In the event of a missed impact reduction between 0 and 3% includes, a weight penalty proportional to the missed reduction will be applied as defined in the measurement protocol.
- (ii) In the event of a missed impact reduction between >3% and 5%, a button will be removed.
- (iii) In the event of a missed impact reduction of more than 5%, the number of new foils pair will be 1.

APPENDIX H MEASUREMENT TRIM

Getting the **boat** into measurement trim shall be the responsibility of the skipper or their designated representative who must sign the checklist.

Each item of the **boat**'s equipment shall be stowed in the position it would be in for use *when racing*, in agreement with the CM.

On condition that the CM has approved it, the weight which shall not be included in the weight of the **boat** in measurement trim is that of all items of equipment that :

- produce renewable energy to charge the batteries without using any type of fuel (hydrogenerator, solar panel, wind generator, etc.) ;

- are made of an alternative material, weighing a maximum of 100 kg and which can be removed ;
- are removable scientific equipment.

For each section below, a set of photos shall be supplied.

These photos are elements of proof for the measurement file.

BOAT EXTERIOR :

- the spars, all standing rigging, all running rigging, associated equipment and fittings ;
- all halyards brought back to the foot of the mast (with their halyard locks if they are equipped with them) ;
- all the furling drums in position with their fittings and associated running rigging ;
- all deck hardware and deck gear, fixed and all clew point adjustments systems ;
- lifelines, pulpits and pushpits, stanchions, navigation lights ;
- mobile cockpit protection, if any, in the closed position (solid and/or fabric protection) ;
- any fairing elements, either soft or rigid ;
- cabling and antennas associated with the VHF and AIS systems ;
- working radar installed ;
- electronic equipment powered electrically or otherwise, installed (various antennas, etc.) ;
- connections for all equipment, installed (autopilot, electronics, computer, etc.) ;
- keel in the middle (0°) ;
- hull appendages in place in their “fully down” position except when their respective positions are defined in a rule or by the CM ;
- rudders in their “fully down” position.

BOAT INTERIOR :

- standardised canting system or any keel canting system ;
- fresh water tanks shall be empty ;
- ballast tanks and associated plumbing shall be empty ;
- all watertight bulkhead hatches and closing mechanisms in place ;
- “main” engine in working order, and if diesel, with its oil and all associated equipment (shaft, propeller, etc.) and diesel generator if any ;
- engine starter (batteries, super capacitors, etc.) with the full charging system ;
- fixed fuel tanks empty except for a small quantity of diesel (5 litres minimum) to be able to use the engine for the needs of the measurement session ;
- all other tank(s) shall be empty except for the hydraulic system reservoirs used in normal sailing mode ;
- service batteries (other than the engine start battery) with their complete charging system in place ;
- the permanently installed electric bilge pump as per C.3.2(b) ;
- its associated fittings and equipment either soft or rigid ;
- navigation seat if a solid item ;
- the number of bunks as per C.10.1(a) & C.10.1(b) ;
- cooking stove, installed and in working order (including fuel) ;
- all the fixed equipment with its accessories and which is used *when racing* shall be in place and in working order (navigation instruments, screens, etc.) ;

AG.4 ENVIRONNEMENTAL IMPACT REDUCTION OF CONSTRUCTIONS

- the two watermakers mentioned in C.10.3 (if one of them is not installed, it shall be placed close to the one installed) ;
- any potential weight penalties.

As a minimum, the items listed in CR C.7.1(a), C.7.2(a), C.7.2(b), C.7.2(e), C.7.2(f), C.7.2(g), C.7.2(h), C.7.2(i) and C.3.14 shall be in working order.

Shall be disembarked :

- the sails ;
- the mainsail lazy jacks ;
- non-permanent hardware and the running rigging not required above ;
- the headsails sheets ;
- the anchoring equipment ;
- safety equipment ;
- outriggers, if any (jockey poles, etc., other than equipment included with the mast) ;
- all movable equipment not connected or attached to the **boat** ;
- all the spare equipment not connected and intended to take place of an installed existing equipment ;
- all consumables, mobile containers and navigational equipment ;
- clothes, food, personal belongings, etc. ;
- communication equipment supplied by TOR and the scientific equipment ;
- in general, any other item of equipment as required by the CM.

APPENDIX I INTERPRETATIONS

These documents are available on the website in the IMOCA "member" section : <https://www.imoca.org/en/technical-committee-documents>.

APPENDIX J ALTERNATIVE MATERIAL

For an item of equipment made of alternative material to be considered removable, it shall be on the "list of removable items" and be approved by the CM.

The skipper or their designated representative shall supply the CM with specific documentation proving that the definition of alternative material has been complied with.

The documentation for each item shall include :

- the 2D/3D drawing for each component which makes up the item ;
- a drawing of its installation ;
- its weight, centre of gravity (CG), its volume if immersed ;
- the traceability of each of its components.

This documentation shall be validated by the CM :

- 1) « documentation » → validation prior to manufacture ;
- 2) « **bateau** » → validation prior to installation on the **boat**.

Thereafter, **modifications** made to this equipment shall be limited to its correct installation or use and must be able to be validated by the CM.

APPENDIX K MEASUREMENT CERTIFICATE AND DOCUMENTS

APPENDIX K-1 IMOCA MEASUREMENT CERTIFICATE

This document is issued by IMOCA and drawn up by the CM (chief.mesureur@imoca.org).

APPENDIX K-2 NEW BUILD DECLARATION FORM

This document is available in the IMOCA "member" section at :
<https://www.imoca.org/en/imoca/official-documents>.

APPENDIX K-3 DOCUMENTS TO BE SUPPLIED TO THE CM TO OBTAIN A MC

The list of documents is listed in the measurement protocol.

APPENDIX K-4 MC RENEWAL FORM

This document is available in the IMOCA "member" section at :
<https://www.imoca.org/en/imoca/official-documents>.

APPENDIX L CONTACTS

Headquarters : IMOCA – Maison des Skippers – 1, Terre-plein du Sous-Marin Papin, 56100 LORIENT – FRANCE

Office :

IMOCA – Maison des Skippers – 1, Terre-plein du Sous-Marin Papin, 56100 LORIENT – France

Tel : +33 (0) 631 435 627

Site Internet IMOCA : www.imoca.org

Président – Antoine MERMOD : president@imoca.org

Administration & Team Liaison : contact@imoca.org

Chef Mesureur – René BOULAIRE : chief.measurer@imoca.org

World Sailing :

Secrétariat Général : secretariat@sailing.org

Jaime NAVARRO – Responsable Technique : jaime.navarro@sailing.org

Suppliers chosen by IMOCA :

AMPM : 16 Rue de la Camamine, 85150 La Mothe-Achard – FRANCE

Contact : Fabien Dillet : +33 (0)2 51 94 76 38 et +33 (0)6 08 36 45 64

CDK : Port la Forêt, 29940 La Forêt Fouesnant – FRANCE

Contact : Michel Ollivier +33 (0)2 98 51 41 00

Gsea Design : 19, rue Jules Guesde, 56100 Lorient – FRANCE

Contact : Benjamin Madec +33 (0)2 97 78 11 91

Hydroem : 4 Rue Eugène Freyssinet, 17140 Lagord – FRANCE

Contact : Michel Farre : +33 (0)6 03 47 93 46

Iridium : Iridium Satellite LLC 1750 Tysons Boulevard, Suite 1400 McLean, VA 22102 – USA

Contact : Dan Rooney dan.rooney@iridium.com

Iroise Rigging : 35 Rue Ingénieur Verrière, 56100 Lorient – FRANCE

Contact : Eric Cochet : +33 (0)6 80 74 63 02

Lorima : 7 Rue du Commandant l'Herminier, Base de Sous-Marins, 56100 Lorient – FRANCE

Contact : Nicolas Rabillé : +33(0) 6 80 23 08 12

Thalès : Thales Defense & Security Inc. 22605 Gateway Center Drive Clarksburg, MD 20871 – USA

Contact : Luciana Valdiviezo luciana.valdiviezo@us.thalesgroup.com

APPENDIX M STANDARDISED BOOM

The standardised boom is supplied by CDK and the calculations are done by Gsea Design.

AM.1 ASSOCIATED PLANS AND DOCUMENTS

AM.1(a) The associated plans and documents in CR **Erreur ! Source du renvoi introuvable.** as well as Note 3 (Manual for the installation and use of the standardised boom) shall be consulted along with the most recent update and/or the most recent version.

These are available in the IMOCA “member” section at : <https://www.imoca.org/fr/login>.

AM.1(b) Note 3 is supplied by the builder upon delivery of the standardised boom.

AM.2 INSTALLATION ON THE BOAT

The skipper shall respect the provisions in Note 3 for the safe and proper use of the standardised boom.

APPENDIX N SAIL IDENTIFICATIONS & LIMITATIONS

AN.1 PRINCIPLES

AN.1(a) From 1st January 2025, the maximum number of active sails associated with a renewable button for each **boat** is 8.

It is expressly permitted to use existing sails.

A **boat** issued with its first MC is given 8 renewable buttons.

AN.1(b) A new button is attributed to a **boat** once an active sail associated with a renewable button becomes existing sail.

AN.1(c) 4 additional non-renewable buttons are attributed in the nine months prior to the start of the « Vendée Globe » for registered **boats**.

AN.1(d) 8 additional non-renewable buttons are attributed in the nine months prior to the start of « The Ocean Race » for registered **boats**.

AN.2 HOW IT WORKS

- AN.2(a)** Each sail shall be referenced via the assignment of a button. The measurements shall be submitted to the CM as defined in the measurement protocol.
- AN.2(b)** The list of buttons associated with each **boat** is available in the IMOCA “member” section at : <https://www.imoca.org/en/login>.
- AN.2(c)** For each race, the skipper or their representative will declare all sails carried on board via the IMOCA “member” platform.
- AN.2(d)** If an active sail is accidentally irrevocably lost or destroyed at sea, a damage report shall be submitted by the skipper or their representative to the CM. The BD will decide whether or not to renew the button associated with this active sail.
- AN.2(e)** Any additional non-renewable button allocated under CR AN.1(c) and AN.1(d) that has not been used in the nine months preceding the race in question is lost.

AN.3 REDUCED IMPACT SAIL

- AN.3(a)** The minimum number of reduced impact sails to be carried on board *when racing* is :
- one for each race of the 2026 « IMOCA Globe Series » Championship ;
 - two for each race of the 2027 and 2028 « IMOCA Globe Series » Championships, except for the « Vendée Globe » ;
 - three for the « Vendée Globe » 2028.
- AN.3(b)** Storm jib and spinnaker are excluded from AN.3(a).

APPENDIX O FOIL LIMITATIONS & IDENTIFICATION

AO.1 PRINCIPLES

- AO.1(a)** For one **boat**, the maximum number of new pairs of foils with which the **boat** can sail over the application period for the 2028 CR is 2.
- AO.1(b)** This limit concerns the principal element of the foil which is defined by the following criteria :
- static moment ;
 - total developed surface area ;
 - measurement weight ;
 - design (structure and geometry).
- AO.1(c)** A new pair of foils is a pair of foils :
- associated with a first MC issued from 1st January 2022 (or 1st January 2021) ;
 - existing ones which become a new pair of foils when there is a variation in the weight criteria greater than +/- 10% compared to the value at the first measurement session.
- AO.1(d)** One sole reproduction of a pair of measured foils is part of the pair of foils from which it came.

AO.1(e) A **boat** which competes in the « The Ocean Race 2023 » is allowed to use an additional pair of new foils.

AO.1(f) Each pair of foils shall have an identification mark defined by IMOCA.

AO.2 HOW IT WORKS

The skipper or their representative shall declare to the CM the pair of foils he uses in each race in the « IMOCA Globe Series » Championship.

APPENDIX P ELECTRONIC EQUIPMENT

Sensor : a device which transforms a detected physical value into a usable value.

For a particular sensor to be authorised, it shall feature in the list below or be approved by the CM.

Model	Supplier
Hydrins	iXblue
Octans Nano	iXblue
Quadrans	iXblue
GEOFOG single antenna	KVH
GEOFOG dual antenna	KVH
Geonyx M	Safran
BlueNaute	Safran

APPENDIX Q MEDIA REPRESENTATIVE (OBR)

The media representative (OBR) shall have recognised experience in the field of content creation. Their application shall be submitted before a race to the IMOCA Class Sporting Commission for approval.

Approval will not normally be granted to a professional sailor, technical specialist, performance specialist, weather specialist, coach or medical professional.

They shall, at the discretion of the IMOCA Class Sporting Commission, attend a preparation and safety course organised by the IMOCA Class.

The role of the media representative (OBR) is specifically to communicate the story of the race and to create any audio, video or visual content for this purpose.

Once the media representative (OBR) has completed the specific tasks related to communication, they may participate in the life of the boat with the crew to the same extent as the other crew members ; with the strict limit of not participating in any action that may influence the conduct or performance of the **boat** such as :

- steering ;
- manœuvring ;
- adjusting ;
- setting parameters ;
- moving sails or equipment in and on the **boat** ;
- analysing the weather ;
- taking part in the strategy ;

- taking part in technical repairs (except for specific communications equipment) ;
- carrying out maintenance or technical monitoring of the **boat** and its systems.

The media representative (OBR) shall be authorised to sound the alarm in the event of a threat or risk of collision with the **boat**.